

Technical Catalogue 2017

Dear Sir/Madam,

Please accept our Technical Catalogue for fire ventilation systems, which contains detailed information on components and technical parameters, as well as the applications, functioning, and methods of installation of the pressurisation systems.

Every appliance dispatched from "MERCOR" S.A. factories to a Customer is thoroughly verified in accordance with the highest quality management standards and subject to a range of approval tests. We are proud to provide safety through our operations.

We are looking forward to doing business with you.

The "MERCOR" S.A. Team

The electronic version of our Technical Catalogue is available at www.mercor.com.pl



FIRE VENTILATION SYSTEM

Fire ventilation systems

Technical Catalogue 2017

Edited by: "MERCOR" S.A. - Fire Ventilation Systems Department

"MERCOR" S.A. seated in Gdańsk reserves the right to introduce any changes to the content of this Technical Catalogue 2017 at any time without notice to the users of this Technical Catalogue 2017.

The content of this Technical Catalogue 2017 is not an offer under art. 66 of the Civil Code.

Desktop publishing: Bliskie strony

© 2017 "MERCOR" S.A. Gdańsk – version 1/2017

PRESSURISATION SYSTEMS

table of contents

requirements

standards and instructions requirements

5

mcr EXi - F

hybrid smoke prevention system
for escape routes

14

Designing smoke prevention systems for vertical and horizontal escape routes is regulated in Poland by:

- **EN 12101-6:2007 Standard** "Smoke and heat control systems. Part 6. Specification for pressure differential systems. Kits". [1]
- **ITB (Building Research Institute) Instruction No. 378/2002** "Designing fire ventilation installations for escape routes in high-rise buildings and skyscrapers." [2]

The designer also has the right to design basing on their own technical expertise, and in consultation with a fire safety expert, assume individual design criteria for a given building.

Regardless of the implemented technical solutions, each of the smoke prevention systems should secure:

- designated positive pressure,
- designated minimum flow velocity in an open door,
- maximum force for opening escape door.

1.1. EN 12101-6 standard requirements

Standard [1] distinguishes system classes that differ in terms of requirements and design basis.

The following table indicates typical application of system classes corresponding to the intended use of the building.

system class	building type
A	Applied mainly in multi-family buildings. Design basis assume that the building shall not be evacuated unless an imminent fire hazard arises.
B	Applied in high-rise buildings and skyscrapers equipped with firefighting lifts and protected lobbies. Most commonly used for office buildings.
C	Applied mainly in office buildings. Design basis assume that the users are conscious, vigilant, and familiar with their surroundings.
D	Applied in buildings in which its users may be asleep, e.g. hotels and guest houses. The system is suitable also for buildings whose users are unfamiliar with its layout or may require assistance in reaching the exits. Also used in buildings in which the staircases, due to architectural limitations, are lacking required protected lobbies.
E	Applied mainly in hospitals and buildings where phased evacuation is used.
F	Applied to reduce the potential of high contamination by smoke on fire escape staircases during evacuations and rescue operations. Used primarily in buildings with lobbies fitted with multiple exits.

Once the building is correctly classified, its system's design must meet the relevant requirements of a given class. The following table indicates the basic criteria for specific system classes. These requirements regulate the efficiency of the air supply unit.

Design criteria

CRITERION: 50 Pa PRESSURE DIFFERENTIAL - between the staircase and the usable area	
klasa systemu	conditions
A	<ol style="list-style-type: none"> 1. All doors between the pressurised staircase and the lobby/corridor are closed. 2. All doors between the pressurised staircase and the final exit are closed. 3. The final exit door is closed. 4. The air release path from the usable area on the storey where the fire was detected is open.
B	<ol style="list-style-type: none"> 1. All doors between the pressurised staircase and the lobby/corridor are closed. 2. All doors between the pressurised staircase and the final exit are closed. 3. The final exit door is closed. 4. The air release path from the usable area on the storey where the fire was detected is open.
C	<ol style="list-style-type: none"> 1. All doors between the pressurised staircase and the lobby/corridor are closed. 2. All doors between the pressurised staircase and the final exit are closed. 3. The final exit door is closed. 4. The air release path from the usable area on the storey where the fire was detected is open.

D	<ol style="list-style-type: none"> 1. All doors between the pressurised staircase and the lobby/corridor are closed. 2. All doors between the pressurised staircase and the final exit are closed. 3. The final exit door is closed. 4. The air release path from the usable area on the storey where the fire was detected is open.
E	<ol style="list-style-type: none"> 1. All doors between the pressurised staircase and the lobby/corridor are closed. 2. All doors between the pressurised staircase and the final exit are closed. 3. The final exit door is closed. 4. The air release path from the usable area on the storey where the fire was detected is open.
F	<ol style="list-style-type: none"> 1. All doors between the pressurised staircase and the lobby/corridor are closed. 2. All doors between the pressurised staircase and the final exit are closed. 3. The final exit door is closed. 4. The air release path from the usable area on the storey where the fire was detected is open.

CRITERION: 10 Pa PRESSURE DIFFERENTIAL - between the staircase and the usable area	
system class	conditions
A	Not applicable.
B	Not applicable.
C	<ol style="list-style-type: none"> 1. The final exit door is open. 2. The doors between usable area and pressurised area are closed on all storeys. 3. All doors between the pressurised staircase and the final exit are closed. 4. The air release path from the usable area on the storey where the fire was detected is open.
D	<ol style="list-style-type: none"> 1. The door between usable area and pressurised area are closed on the storey covered by the fire. 2. The final exit door is open. 3. The doors to storeys other than the storey covered by the fire are open. 4. The air release path from the usable area on the storey where the fire was detected is open.
E	<ol style="list-style-type: none"> 1. The doors between usable area and pressurised area are closed on the storey covered by the fire. 2. The final exit door is open. 3. The doors between usable area and pressurised area are open on the two adjacent storeys. 4. The air release path from the usable area on the storey where the fire was detected is open.
F	Not applicable.

CRITERION: PRESSURE DIFFERENTIAL - between the lobby and the usable area	
system class	conditions
A	No requirements. If the building is fitted with lobbies: securing the pressure difference of 45 Pa on both sides of closed door between the lobby and the usable area.
B	Securing a pressure difference of 45 Pa on both sides of closed doors between the lobby and the usable area.
C	No requirements. If the building is fitted with lobbies: securing the pressure difference of 45 Pa on both sides of closed door between the lobby and the usable area.
D	No requirements. If the building is fitted with lobbies: securing the pressure difference of 45 Pa on both sides of closed door between the lobby and the usable area.
E	No requirements. If the building is fitted with lobbies: securing the pressure difference of 45 Pa on both sides of closed door between the lobby and the usable area.
F	Securing a pressure difference of 45 Pa on both sides of closed doors between the lobby and the usable area.

CRITERION: AIRFLOW - between the pressurised area and the usable area	
system class	conditions
A	The airflow through the door opening between the pressurised area and the usable area shall be not less than 0.75 m/s when: <ol style="list-style-type: none"> 1. the door between the staircase and the usable area is open on the storey where the fire is detected, 2. all doors except the door on the storey covered by the fire are closed, 3. the air release path from the usable area on the storey where the fire was detected is open.
B	Not applicable.
C	The airflow through the door opening between the pressurised area and the usable area shall be not less than 0.75 m/s when: <ol style="list-style-type: none"> 1. the door between the staircase and the usable area is open on the storey where the fire is detected, 2. all doors except the door on the storey covered by the fire are closed, 3. the air release path from the usable area on the storey where the fire was detected is open.
D	The airflow through the door opening between the pressurised area and the usable area shall be not less than 0.75 m/s when: <ol style="list-style-type: none"> 1. the door between the staircase and the usable area is open on the storey where the fire is detected, 2. the final exit door is open, 3. all doors except the door on the storey covered by the fire and the final exit are closed, 4. the air release path from the usable area on the storey where the fire was detected is open.
E	The airflow through the door opening between the pressurised area and the usable area shall be not less than 0.75 m/s when: <ol style="list-style-type: none"> 1. the door between the staircase and the usable area is open on the storey where the fire is detected, 2. the door between the staircase and the usable area is open on the storey above the storey where the fire is detected, 3. the final exit door is open, 4. all doors except the door on the storey covered by the fire and the final exit are closed, 5. the air release path from the usable area on the storey where the fire was detected is open.
F	The airflow through the door opening between the staircase and the lobby on the storey where the fire is detected shall not be less than 2 m/s when the door is open: <ol style="list-style-type: none"> 1. between the lobby and the fire zone covered by the fire, 2. between the staircase and the lobby beneath the storey covered by the fire, 3. between the firefighting lift shaft and the lobby on the storey beneath the storey covered by the fire, 4. between the staircase and the surroundings on the firefighter access level, 5. between the lobby and the usable area on the storey above the storey covered by the fire, while securing the release of air on the storey where the fire is detected.

CRITERION: AIRFLOW - between the lobby and the usable area	
system class	conditions
A	Not applicable.
B	The airflow through the door opening between the lobby and the usable area on the storey where the fire is detected shall not be less than 2 m/s when the door is open: <ol style="list-style-type: none"> 1. between the staircase and the lobby on the storey covered by the fire, 2. between the staircase and the lobby on the adjacent storey, 3. between the firefighting lift shaft and the lobby on the adjacent storey, 4. between the staircase and the surroundings on the firefighter access level, while securing the release of air on the storey where the fire is detected.
C	Not applicable.
D	Not applicable.
E	Not applicable.

F	<p>The air supply shall be sufficient to maintain the minimum airflow of 1 m/s through all open doors between the lobby and the zone covered by the fire when:</p> <ol style="list-style-type: none"> 1. the door between the staircase and the lobby is closed, 2. all doors between the lobby and the adjacent usable areas on the storey covered by the fire are open, 3. the door between the staircase and the surroundings on the firefighter access level is open; does not apply if there is an ordinary lobby between the staircase and the final exit door, 4. the air release path from the storey where the fire was detected is open.
----------	--

CRITERION: LIFT SHAFT	
system class	conditions
A	If the lift is accessed through the lobby or a non-pressurised corridor, the pressure in the shaft should be increased to the same level as in the staircase.
B	Minimum pressure differential between the firefighting lift shaft and the usable area is 50 Pa.
C	If the lift is accessed through the lobby or a non-pressurised corridor, the pressure in the shaft should be increased to the same level as in the staircase.
D	If the lift is accessed through the lobby or a non-pressurised corridor, the pressure in the shaft should be increased to the same level as in the staircase.
E	If the lift is accessed through the lobby or a non-pressurised corridor, the pressure in the shaft should be increased to the same level as in the staircase.
F	Minimum pressure differential between the firefighting lift shaft and the usable area is 50 Pa.

CRITERION: DOOR OPENING FORCE	
system class	conditions
A	The force on the door handle must not exceed 100 N.
B	The force on the door handle must not exceed 100 N.
C	The force on the door handle must not exceed 100 N.
D	The force on the door handle must not exceed 100 N.
E	The force on the door handle must not exceed 100 N.
F	The force on the door handle must not exceed 100 N.

Diagrams of design requirements for different system classes (pp. 9, 10)

1. door open
2. door closed
3. air release path
4. protected lobby
5. airflow from the lift shaft

A-class system

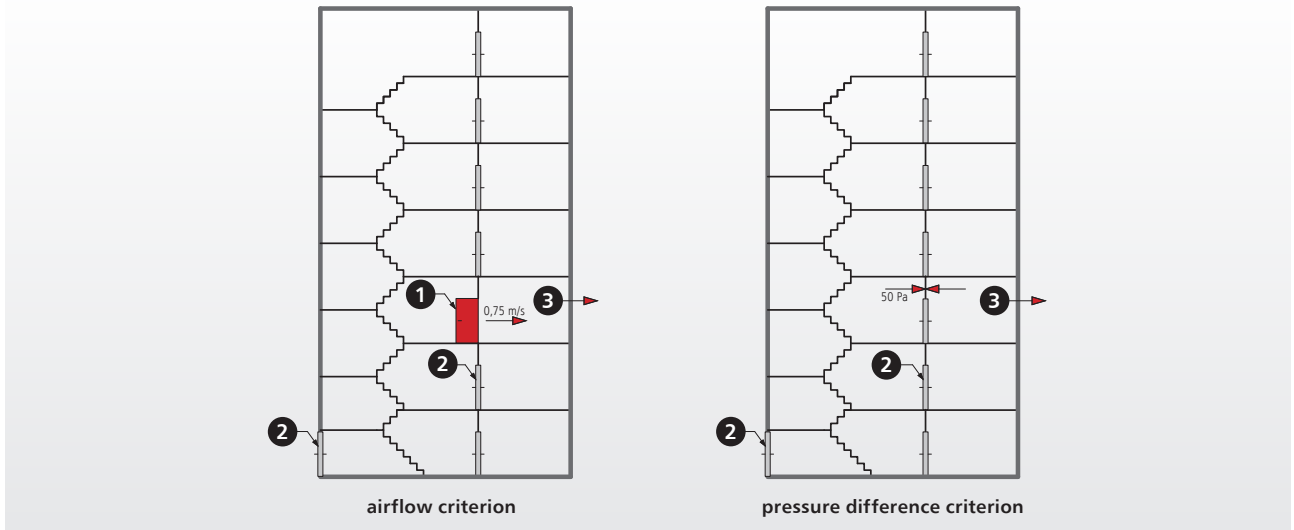

B-class system

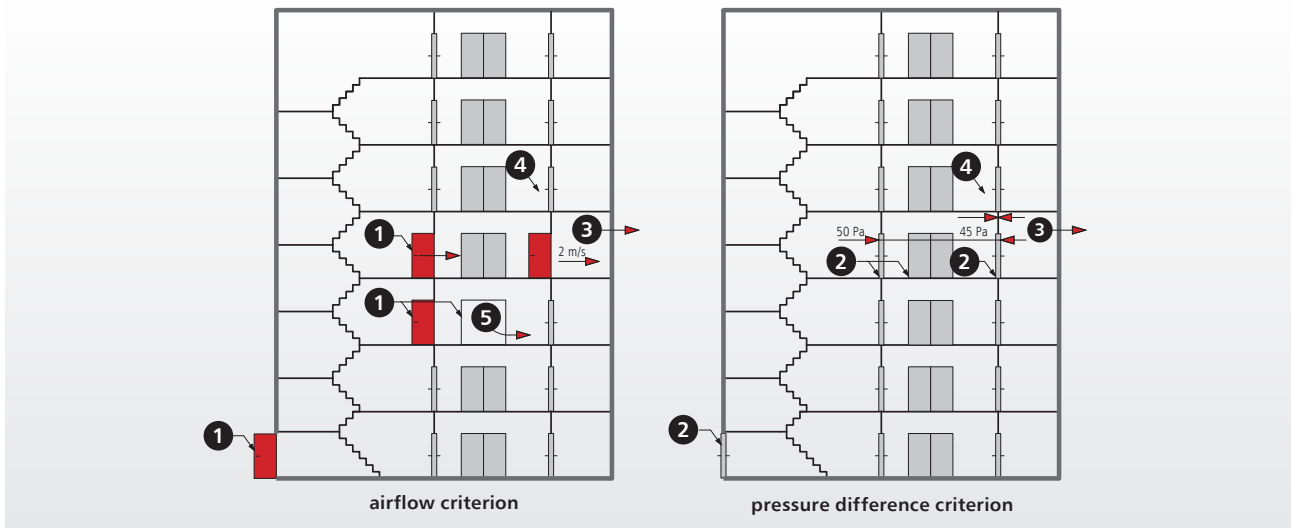

C-class system

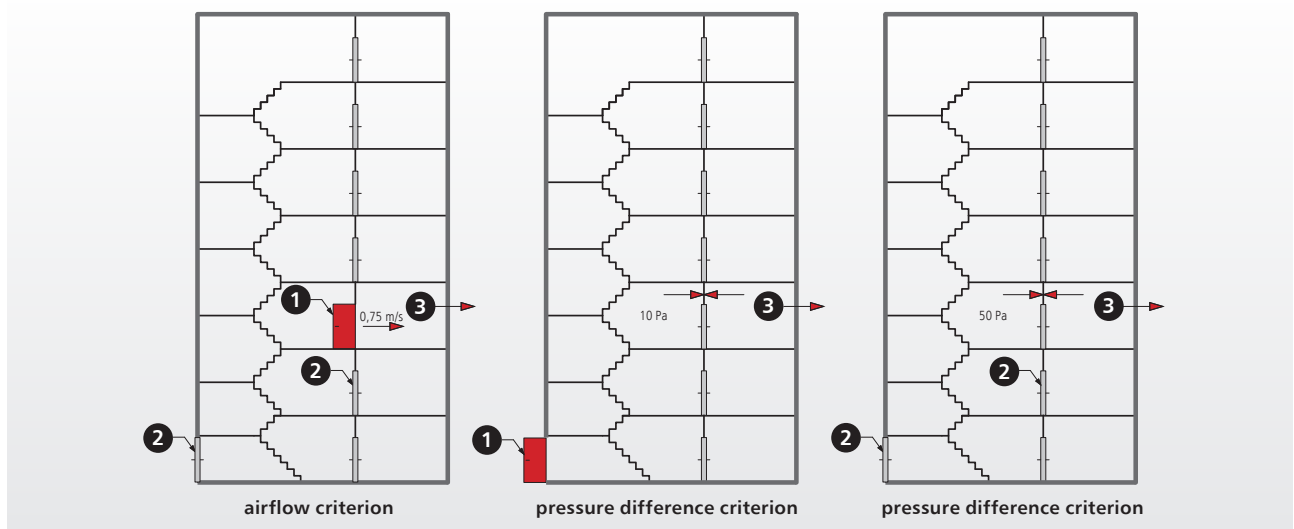

D-class system

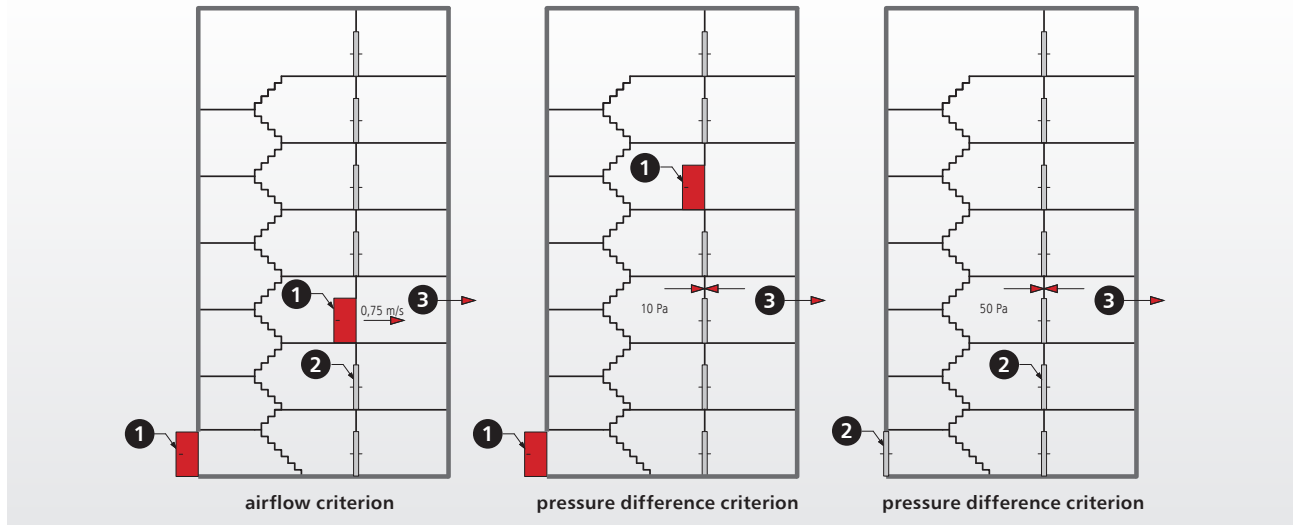

E-class system

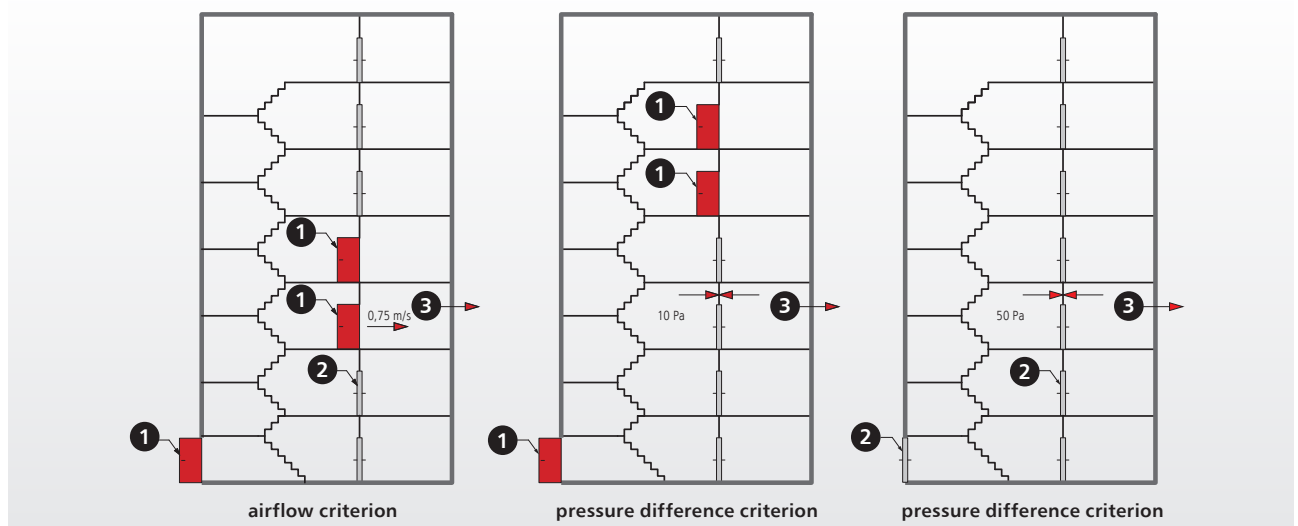

F-class system

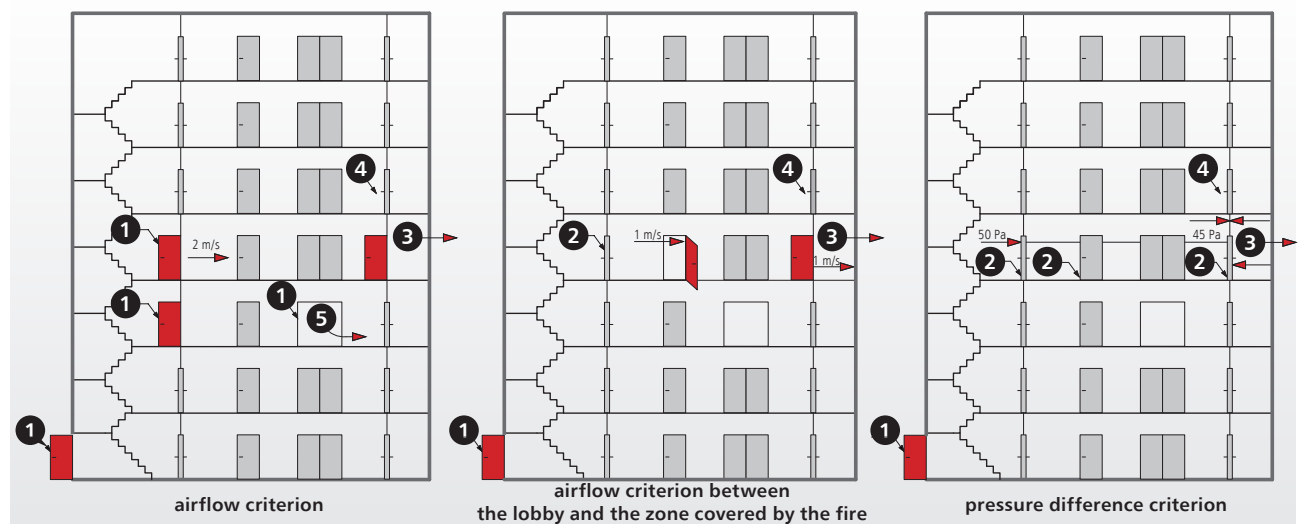

1.2. ITB 378/2002 Instruction requirements

The Instruction [2] distinguishes two types of escape routes protection, defined as solutions A and B. These solutions comprise smoke protection measures for the staircase and protected lobbies, as well as smoke ventilation of escape corridors. The following table presents the design criteria for these systems.

Design criteria

CRITERION: STAIRCASE SMOKE PREVENTION MEASURES	
system class	conditions
Solution A	<p>The smoke prevention system provides:</p> <ol style="list-style-type: none"> the pressure differential of $20 \div 80$ Pa between the staircase and a corridor assuming that: <ul style="list-style-type: none"> all doors between the pressurised staircase and lobbies are closed, the final exit door is closed, the airflow not less than 0.5 m/s: <ul style="list-style-type: none"> through the open staircase doors on the storey covered by the fire with the door to the protected lobby open, through the open door of the final exit door of the staircase.
Solution B	<p>The smoke prevention system provides:</p> <ol style="list-style-type: none"> the pressure differential of $20 \div 80$ Pa between the staircase and a corridor assuming that: <ul style="list-style-type: none"> all doors between the pressurised staircase and lobbies are closed, the final exit door is closed, the airflow not less than 0.5 m/s: <ul style="list-style-type: none"> through the open staircase door on the storey covered by the fire with the door to the protected lobby open, through the open door of the final exit of the staircase.

CRITERION: PROTECTED LOBBY SMOKE PREVENTION MEASURES	
system class	conditions
Solution A	<ol style="list-style-type: none"> Air supply to the lobby at $\geq 720 \text{ m}^3/\text{h}/\text{m}^2$. Efficiency of the mechanical exhaust from the lobby at $\geq 90\%$ of the air supply. Pressurisation in the lobby in relation to the staircase and the escape corridor in case the door to the lobby is closed.
Solution B	<ol style="list-style-type: none"> Air supply to the lobby sufficient to maintain the airflow of 1 m/s through the open door between the lobby and an escape corridor (taking into account the air supplied through the open door between the staircase and the lobby). Airflow from the lobby to a corridor through the fire transfer dampers situated in the wall between the lobby and a corridor. Minimum airflow of 1 m/s through the open door between the lobby and a corridor with the door between the lobby and the staircase open. Pressurisation in the lobby in relation to the staircase and the escape corridor in case the door to the lobby is closed.

CRITERION: SMOKE EVACUATION OF ESCAPE CORRIDORS	
system class	conditions
Solution A	<ol style="list-style-type: none"> Direct air supply to a corridor. Airflow ≤ 5 m/s. Minimum air supply of $3600 \text{ m}^3/\text{h}$. Smoke ventilation system efficiency $\geq 130\%$ of air supply. Securing distance between the smoke extracting and air supply grills as defined in the ITB Instruction.
Solution B	<ol style="list-style-type: none"> Direct air supply from a corridor through a fire transfer damper in the wall between the lobby and the corridor, air velocity at the damper ≤ 5 m/s. Smoke ventilation system efficiency $\geq 130\%$ of air supply. Securing distance between the smoke extracting and air supply grills as defined in the ITB Instruction.

CRITERION: ENTRANCE HALL SMOKE PREVENTION MEASURES	
system class	conditions
Solution A	1. Mechanical exhaust ventilation system with efficiency not less than 3600 m ³ /h for every 100 m ² of the hall surface. However, not less than 5400 m ³ /h. 2. Type of supply system determined by the height of the hall: a) h ≤ 5 m - mechanical air supply, - efficiency of the air supply reduced by 30% in relation to the exhaust, b) h ≥ 5m - gravity air supply, - size of the air supply openings adjusted for a flow not larger than 5 m/s at the air supply grill.
Solution B	1. Mechanical exhaust ventilation system with efficiency not less than 3600 m ³ /h for every 100 m ² of the hall surface. However, not less than 5400 m ³ /h. 2. Type of supply system determined by the height of the hall: a) h ≤ 5 m - mechanical air supply, - efficiency of the air supply reduced by 30% in relation to the exhaust, b) h ≥ 5m - gravity air supply, - size of the air supply openings adjusted for a flow not larger than 5 m/s at the air supply grill.

CRITERION: LIFT SHAFT SMOKE PREVENTION MEASURES	
system class	conditions
Solution A	Pressure differential between the firefighting lift shaft and the usable area should be approx. 50 Pa.
Solution B	Pressure differential between the firefighting lift shaft and the usable area should be approx. 50 Pa.

Smoke prevention of escape routes may use fire ventilation systems that combine both A and B solutions.

Diagrams of design requirements for solutions A and B

Solution A

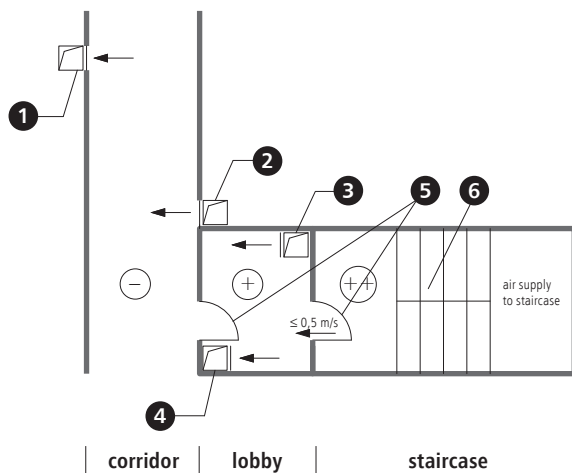

Airflow criterion:

1. exhaust: efficiency ≥ 130% of air supply efficiency
2. air supply: air velocity ≤ 5 m/s, min. airflow 3600 m³/h
3. air supply ≥ 720 m³/h/m² of lobby
4. exhaust ≥ 90% of air supply
5. door open

Pressure difference criterion:

1. exhaust: efficiency ≥ 130% of air supply efficiency
2. air supply: air velocity ≤ 5 m/s, min. airflow 3600 m³/h
3. air supply ≥ 720 m³/h/m² of lobby
4. exhaust ≥ 90% of air supply
5. door closed
6. pressure 20-80 Pa in relation to the reference point

Solution B

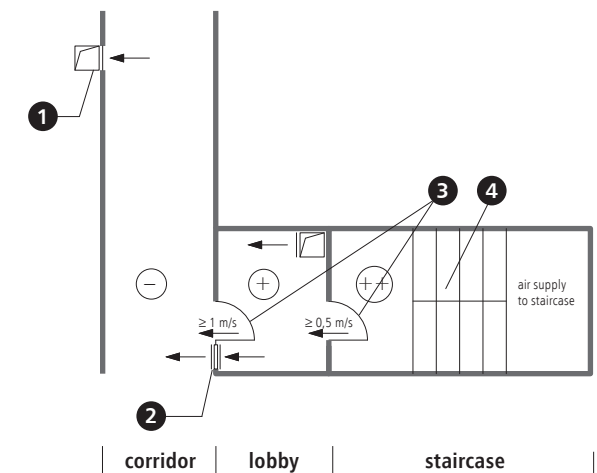

Airflow criterion:

1. exhaust: efficiency ≥ 130% of air supply efficiency
2. air supply: air velocity ≤ 5 m/s (transfer fire damper)
3. door open

Pressure difference criterion:

1. exhaust: efficiency ≥ 130% of air supply efficiency
2. air supply: air velocity ≤ 5 m/s (transfer fire damper)
3. door closed
4. pressure 20-80 Pa in relation to the reference point

1.3. requirements regarding fire ventilation system design

The Standard [1] and the Instruction [2] lay down the requirements for fire ventilation system. The following table presents the basic guidelines that are to be taken into in design of such system.

Design guidelines

STAIRCASE AIR SUPPLY POINTS		
	EN 12101-6:2007	ITB Instruction No. 378/2002
Height of the building < 11 m	Single-point air supply allowable.	Single- and multi-point air supply possible.
Height of the building ≥ 11 m	Multi-point air supply. Maximum distance between the air supply points: three storeys.	Single- and multi-point air supply possible.

LIFT SHAFT AIR SUPPLY POINTS		
	EN 12101-6:2007	ITB Instruction No. 378/2002
Shaft height ≤ 30 m	Single air supply point.	Single-point air supply possible.
Shaft height > 30 m	Two air supply points.	Single-point air supply possible.

AIR INLET LOCATION FOR AIR SUPPLY UNITS		
	EN 12101-6:2007	ITB Instruction No. 378/2002
Roof air inlets	Two intakes, oriented in different directions required, i.e. the so-called "twin intake terminal reconnecting system". Each of the intakes should independently provide full air supply necessary for the system. Intakes are protected with an air damper and equipped with in-duct smoke detectors. If one of the intakes is contaminated with smoke, the system switches to the opposite inlet. A smoke exhaust should be located minimum 1 m above the air inlet and not closer than 5 m away from the inlet.	Requirements not specified. Single inlet possible.
Air inlet on remaining storeys	Wall-mounted inlets require a single intake equipped with an air damper and an in-duct smoke detector.	Requirements not specified.

AIR RELEASE FROM USABLE AREA ENABLING AIR DISCHARGE TO THE OUTSIDE OF THE BUILDING		
	EN 12101-6:2007	ITB Instruction No. 378/2002
Gravity release	<ol style="list-style-type: none"> 1. Windows with certified fire-rated actuator. 2. Vertical shaft with cross-sectional dimensions that provide the velocity of air flow not over 2 m/s or determined by pressure losses. 3. Pressure losses along the route of the air from the area protected by positive pressure to the external outlet cannot exceed 40 Pa. 	Instruction does not provide for use of gravity exhaust
Mechanical release	<ol style="list-style-type: none"> 1. Smoke evacuation system. 	Mechanical smoke evacuation system required.

BACK-UP FANS		
	EN 12101-6:2007	ITB Instruction No. 378/2002
Staircase is the only escape route	Back-up fan required.	No requirements.
Min. two staircases provide escape routes from each of the storeys	Back-up fan not required.	No requirements.



ITB[®]
CERTYFIKACJA PRODUKTU



- ▶ ITB-2469/W Certificate of Conformity.
- ▶ ITB AT-15-9674/2016 Technical Approval.
- ▶ Electronic system with the characteristics of a mechanical system.
- ▶ Air supply units operating indoors and outdoors, positioned both vertically and horizontally.
- ▶ 12 types of systems - a wide variety of applications.
- ▶ Intuitive service and simplicity of operations – ease of design and selection appropriate devices.
- ▶ Adjustment, settings and monitoring of system's operations accessible via dedicated service application.
- ▶ Integrated, internal and autonomous mechanism of rapid adaptation of actions enabling quicker commissioning of the system on site.

2.1. system application

The mcr EXi-F system is designed to secure any type of protected areas (staircases, lift shafts, lobbies, escape corridors) through positive pressure. The system comprises a configured set of devices that create positive pressure, which prevents the smoke from penetrating protected areas. Depending on the needs, the air can be delivered to the protected areas through a single- or multi-point air supply. The sets of devices can operate both indoors and outdoors, with the fans oriented either vertically or horizontally (installed on rooftops, in the walls, etc.).

mcr EXi-F system includes:

- air supply unit(s) with additional equipment (air dampers, inlets, exhausts, grills, etc.),
- mcr Omega power and control unit (TZS Omega),
- mcr ICR pressure controller (part of the mcr Omega control unit)
- differential pressure converter(s):
 - mcr ICS digital pressure converter,
 - 984M analogue pressure converter.

mcr EXi-F system's additional elements:

- PSR manual control panel,
- U2 intake terminal reconnecting system (air dampers and actuators),
- in-duct smoke detectors (for indoor and outdoor operations),
- mcr PL and mcr PLD overpressure-relief dampers (additional unsealing of the system),
- mcr RPC permanent unseal of the system.

2.2. description of system operation

mcr EXi-F system operation is managed by the mcr Omega power and control unit (3). The positive pressure system is activated with a signal from SAP. Once the detection of fire in the building is signalled:

- air dampers at the air supply units open (1),
- air release path opens from the usable area of the storey covered by the fire (5),
- air supply units are activated (1),
- permanent unseal is opened (2) or (7) (if part of the system).

System can also be launched manually from the mcr Omega control unit or from the PSR manual control panel (6). Several seconds after fire is detected the protected area is filled with air and, as a result, a pressure difference between the area and the adjacent areas appears.

The required positive pressure is adjusted by supplying adequate airflow to the protected area through a single or multiple air supply unit.

General scheme of the system

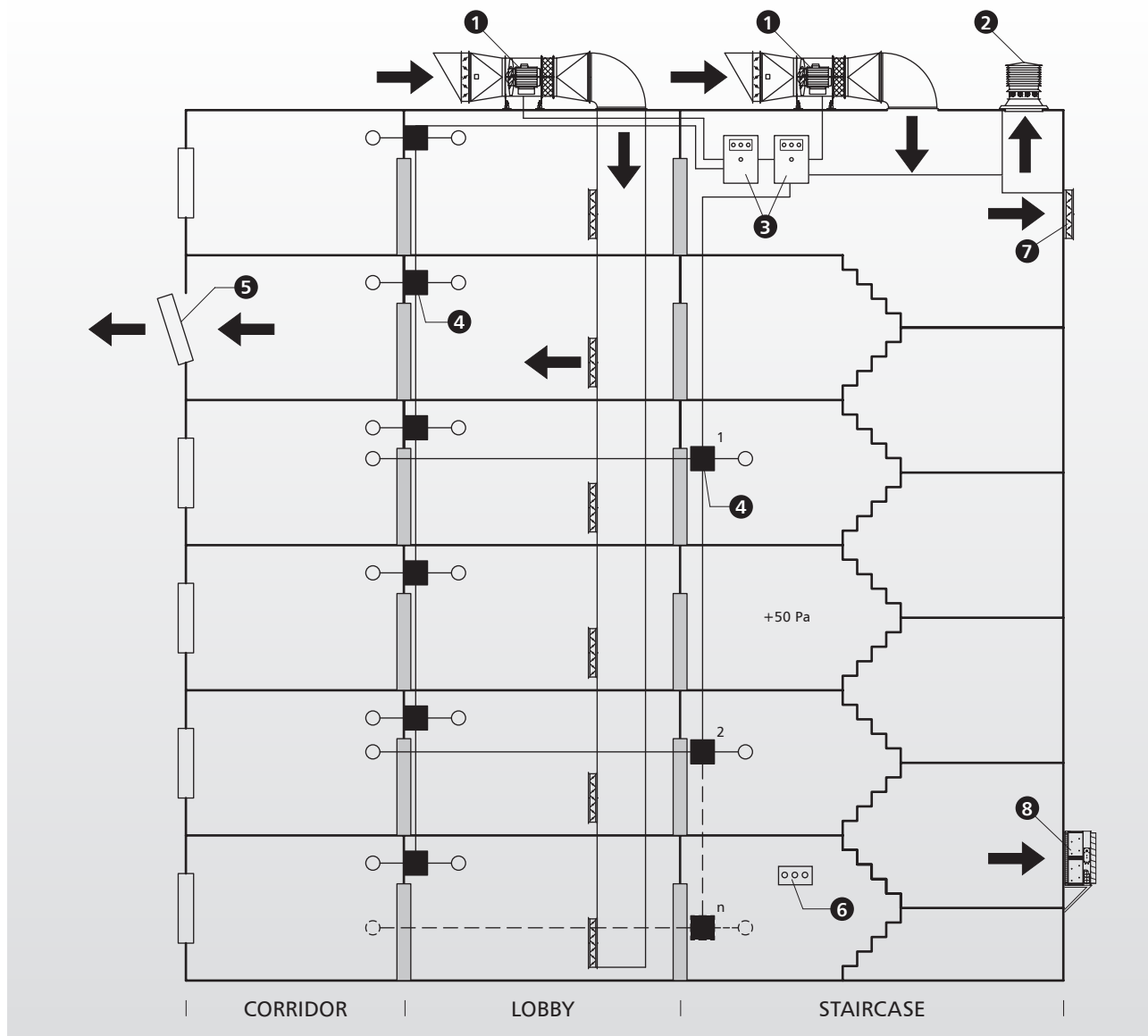

- | | | |
|---|------------------------------------|--|
| 1. air supply unit with air damper and smoke detector | 4. differential pressure converter | 7. mcr LAM louvre damper (optional) |
| 2. unseal of protected area mcr RPC (optional) | 5. air release | 8. overpressure-relief damper (optional) |
| 3. mcr Omega power and control unit(s) | 6. PSR manual control panel | |

If the door to the protected zone is closed, the main component of the air supply unit (1), i.e. the fan, supplies the required, stable airflow. The current pressure value in the protected area is measured and controlled using a single or multiple pressure converters (4). The predefined level of positive pressure created in the protected area ensures that the force required to open escape door does not exceed 100 N. Upon opening the door, and causing the pressure drop in the protected zone, the fan increases its speed (system reaction below 3 seconds) ensuring adequate design value of the airflow through the door between the protected zone and adjacent areas.

For the velocity of airflow to achieve the required value it is necessary to secure air release(s) (5) to the external environment using one of the following solutions:

- opening in the external wall (e.g. automatically opened windows - mcr OSO system, slot grills),
- exhaust shaft equipped with fire dampers (e.g. mcr FID S, mcr WIP, mcr WIP PRO) on every storey's connecting points,
- mechanical exhaust, specially designed and controlled, topped with a smoke-exhaust fan (e.g. mcr Pasat or mcr Monsun).

The cut-off air damper constitutes one of components of the air supply unit. The air damper remains closed during system standby and opens during a fire alarm. The air supply unit may be equipped with the in-duct smoke detector. In case the detector signals smoke contamination of the air, the fan is stopped and the air damper closes. If the air intake is located on the roof, the guidelines of the standard [1] require using two opposing air intakes, each equipped with an air damper and a smoke detector. If smoke contamination of the air is detected in one intake, its damper closes, while and the air damper of the opposing intake opens (U2 twin intake terminal reconnecting system).

The cut-off air damper constitutes one of components of the air supply unit. The air damper remains closed during system standby and opens during a fire alarm. The air supply unit may be equipped with the in-duct smoke detector. In case the detector signals smoke contamination of the air, the fan is stopped and the air damper closes. If the air intake is located on the roof, the guidelines of the standard [1] require using two opposing air intakes, each equipped with an air damper and a smoke detector. If smoke contamination of the air is detected in one intake, its damper closes, and the air damper of the opposing intake opens (U2 twin intake terminal reconnecting system).

The efficiency of the air supply unit protecting a given area from smoke is determined by the designer. When choosing air supply unit for any certified positive pressure system, the condition of the minimum efficiency of air supply unit should also be consulted. This value determines the minimum leakage of the protected area required for meeting the criteria of system's correct functioning (maximum reaction time to changing conditions during the evacuation). In sealed protected areas, which require high efficiency of air supply units (such as a staircase with low number of large doors), the leakage surface may be too small to meet the requirements. In such case it is necessary to additionally unseal the protected area. This can be done using any opening in the external wall or the roof of the smoke-protected area. The unsealing opening should be normally closed, in order to prevent cooling, and it should be opened during a fire alarm.

For unsealing the mcr EXi-F system uses:

- roof exhaust with multi-blade air damper with mcr RPC (2), fire-rated actuator,
- mcr LAM (7) louvre damper.

If providing the required operating parameters for the system is difficult to achieve, using overpressure-relief dampers (8) with proper operating threshold may be advisable.

2.3. system components

2.3.1. air supply units

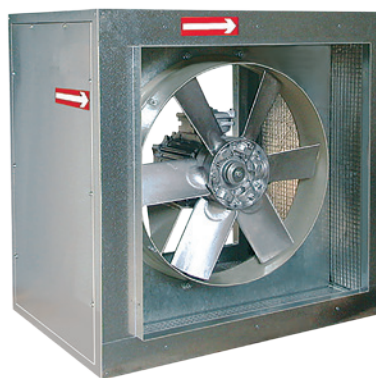

mcr EXi-F system's air supply units comprise following devices:

- mcr Monsun BO axial fan in cylindrical housing or mcr Monsun E in box housing, with optional additional equipment,
- multi-blade air damper with BFN/BFL/BLF/BF/BLE/BE or NF series actuator (optional),
- in-duct smoke detector for indoors and outdoors operations (optional),
- mcr LAM damper (e.g. for vertical fans installation in box housings),
- flanged confusor, „bird beak“ duct with net, etc.

The purpose of air supply units is to deliver sufficient quantities of air in order to meet the design requirements. The fans can be installed indoors or outdoors, with the fan axis oriented vertically or horizontally.

2.3.1.1. design, dimensions

mcr Monsun BO axial fan in cylindrical housing design

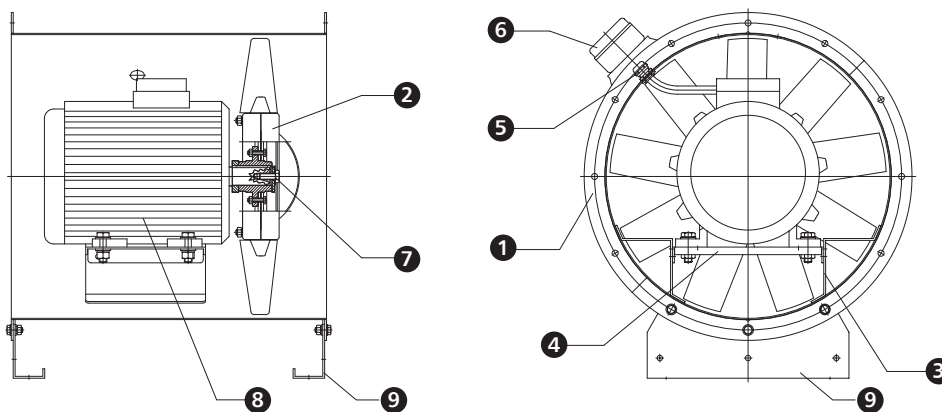

- | | | |
|-------------------|-----------------|------------------------|
| 1. fan housing | 4. motor base | 7. impeller protection |
| 2. axial impeller | 5. cable gland | 8. electric motor |
| 3. base support | 6. terminal box | 9. mounting foot |

mcr Monsun BO axial intake fans have a cylindrical housing with connection flanges for ventilation system. The electric motor is placed on a support inside the housing. The impeller is mounted directly on the pivot of the motor. The motor is connected to electrical cables through a terminal box placed on the housing of the mcr Monsun BO.

mcr Monsun E intake fans feature a steel sheet box housing with internal, mineral wool insulation layer. The housing is equipped with connection elements. Electric motor is placed on a support inside the housing. The impeller is mounted directly on the pivot of the motor. The terminal box of the mcr Monsun E fan is located directly on the housing.

mcr Monsun E in box housing design

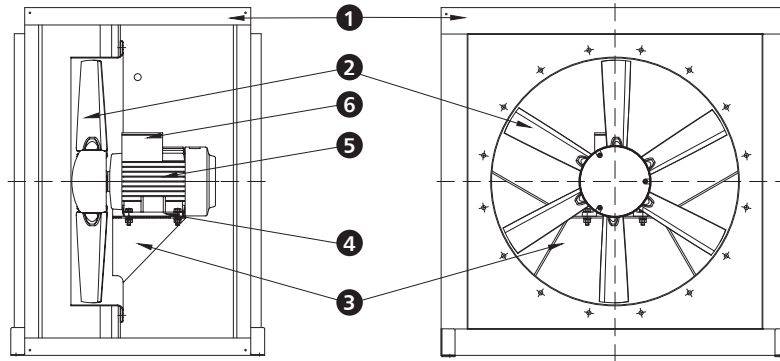

- 1. sound insulated fan housing
- 2. axial impeller
- 3. motor base support
- 4. motor base
- 5. electric motor
- 6. terminal box

Basic dimensions of mcr EXi-F system's air supply units in cylindrical housings

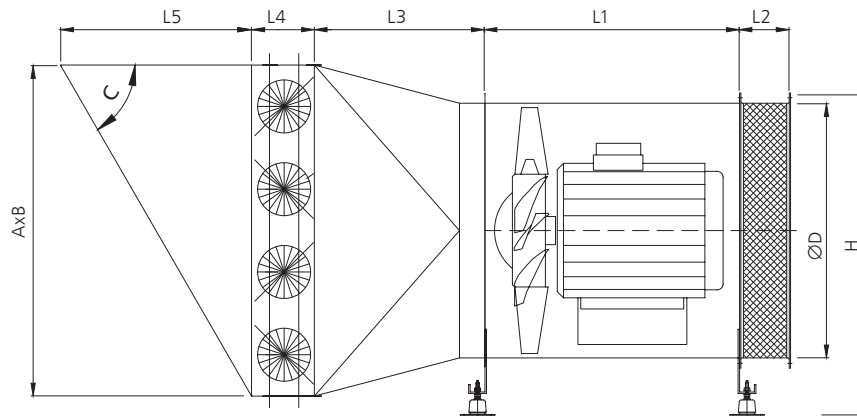

system type	D [mm]	~H [mm]	A [mm]	B [mm]	~L1 [mm]	~L2 [mm]	L3 [mm]	L4 [mm]	~L5 [mm]	C [°]	~weight [kg]
mcr EXi-F 100-1M	1000	1260	1300	1300	1000	200	700	115	870	60	355
mcr EXi-F 90-1M	900	1160	1300	1300	900	200	700	115	870	60	296
mcr EXi-F 80-1M	800	1060	1200	1200	750	200	700	115	810	60	257
mcr EXi-F 71-1M	710	970	1100	1100	750	200	700	115	755	60	205
mcr EXi-F 63-1M	630	850	800	800	600	200	500	115	580	60	123
mcr EXi-F 63-2M	630	850	800	800	600	200	500	115	580	60	116
mcr EXi-F 56-1M	560	770	800	800	700	150	500	115	580	60	110
mcr EXi-F 50-1M	500	710	800	800	600	150	500	115	580	60	86

Mounting dimensions of mcr EXi-F system's air supply units in cylindrical housings

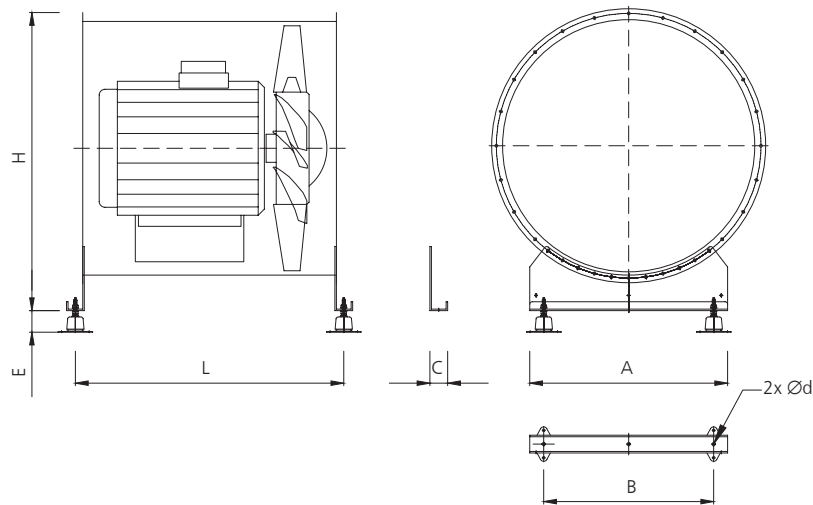

system type	A [mm]	B [mm]	C [mm]	d [mm]	H [mm]	~L [mm]	~E [mm]
mcr EXi-F 100-1M	780	670	70	12,5	1190	1076	85
mcr EXi-F 90-1M	700	620	60	12,5	1065	966	85
mcr EXi-F 80-1M	650	570	50	12,5	965	806	85
mcr EXi-F 71-1M	550	470	50	12,5	870	806	85
mcr EXi-F 63-1M	500	420	50	12,5	780	656	85
mcr EXi-F 63-2M	500	420	50	12,5	780	656	85
mcr EXi-F 56-1M	450	370	50	12,5	695	756	85
mcr EXi-F 50-1M	400	320	50	12,5	640	656	85

Basic dimensions of mcr EXi-F system's air supply units in box housings

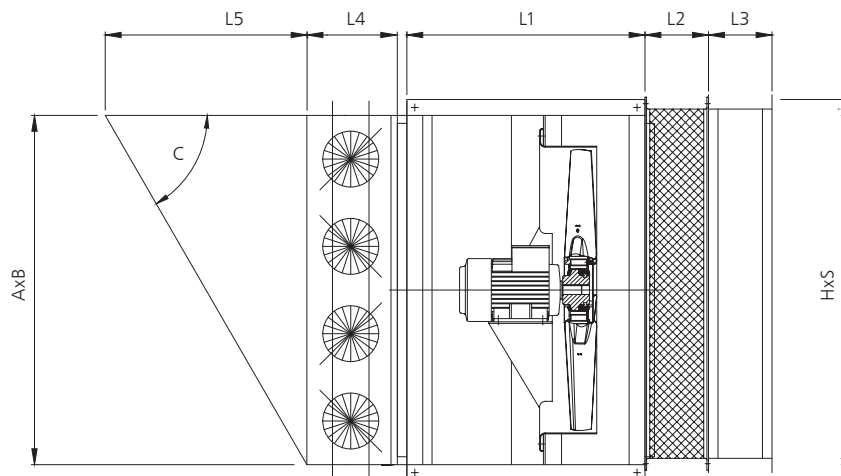

system type	H [mm]	S [mm]	A [mm]	B [mm]	L1 [mm]	~L2 [mm]	L3 [mm]	L4 [mm]	~L5 [mm]	C [°]	~weight [kg]
mcr EXi-F 100-1S	1200	1200	1100	1100	910	130	200	115	755	60	289
mcr EXi-F 90-1S	1200	1200	1100	1100	910	130	200	115	755	60	238
mcr EXi-F 80-1S	1000	1000	900	900	810	130	200	115	640	60	156
mcr EXi-F 63-1S	825	825	700	700	710	130	200	115	525	60	101

Mounting dimensions of mcr EXi-F system's air supply units in box housings

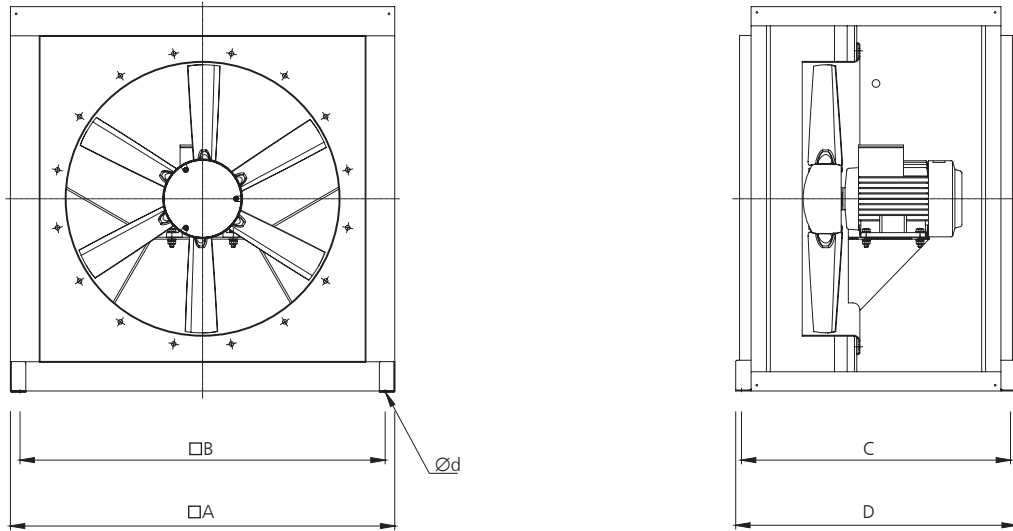

system type	A [mm]	B [mm]	C [mm]	D [mm]	d [mm]
mcr EXi-F 100-1S	1200	1150	860	884	13
mcr EXi-F 90-1S	1200	1150	860	884	13
mcr EXi-F 80-1S	1000	950	760	784	13
mcr EXi-F 63-1S	825	775	660	684	13

Mounting dimensions of mcr EXi-F system's air supply units in box housings – vertical installation with mcr LAM damper

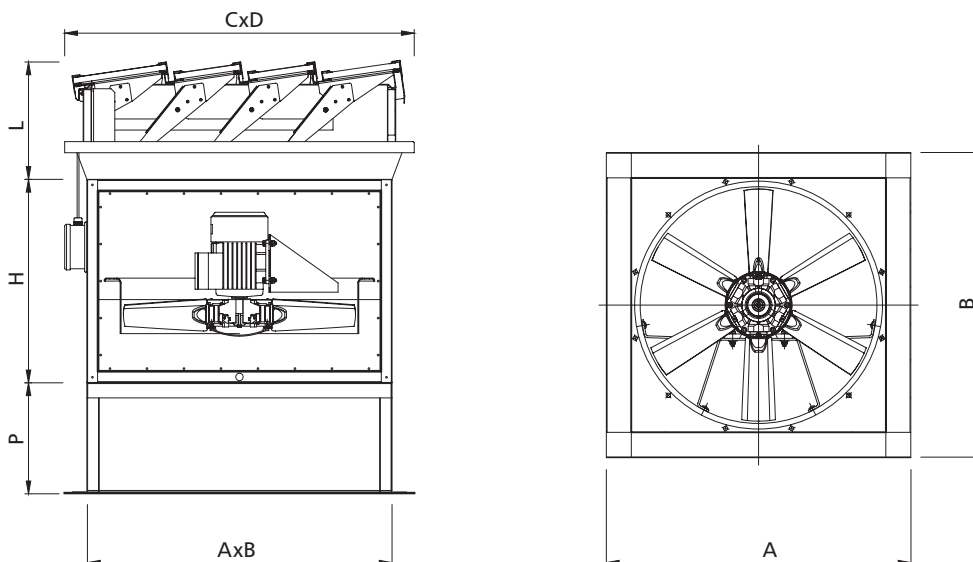

system type	A [mm]	B [mm]	~C [mm]	~D [mm]	P [mm]	H [mm]	~L [mm]	~weight [kg]
mcr EXi-F 100-1S-H	1200	1200	1300	1300	300	750	320	376
mcr EXi-F 90-1S-H	1200	1200	1300	1300	300	750	320	326
mcr EXi-F 80-1S-H	1000	1000	1100	1100	300	650	320	228
mcr EXi-F 63-1S-H	825	825	945	945	300	550	320	157

2.3.1.2. flow characteristics, hydraulic parameters

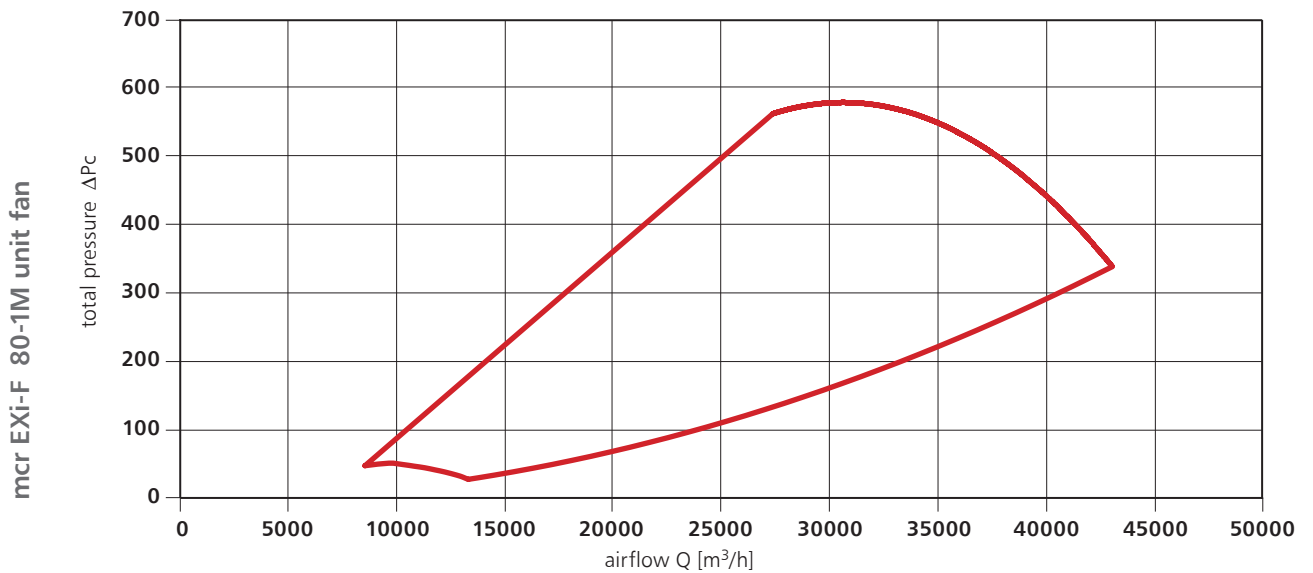
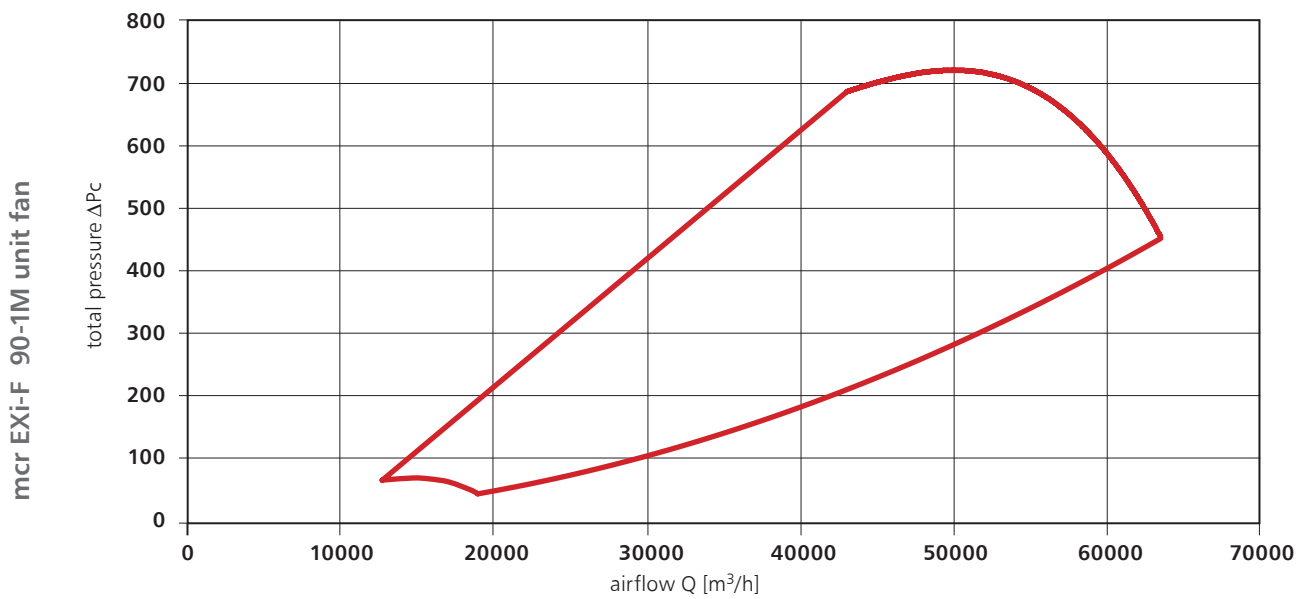
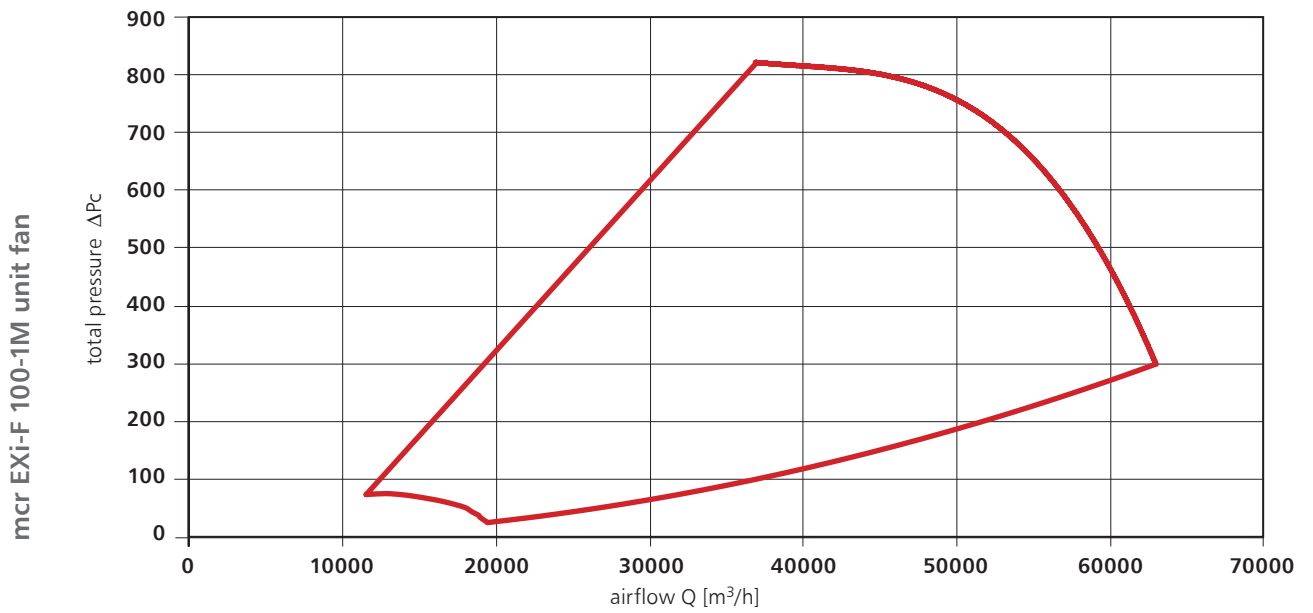

mcr EXi-F 71-1M unit fan

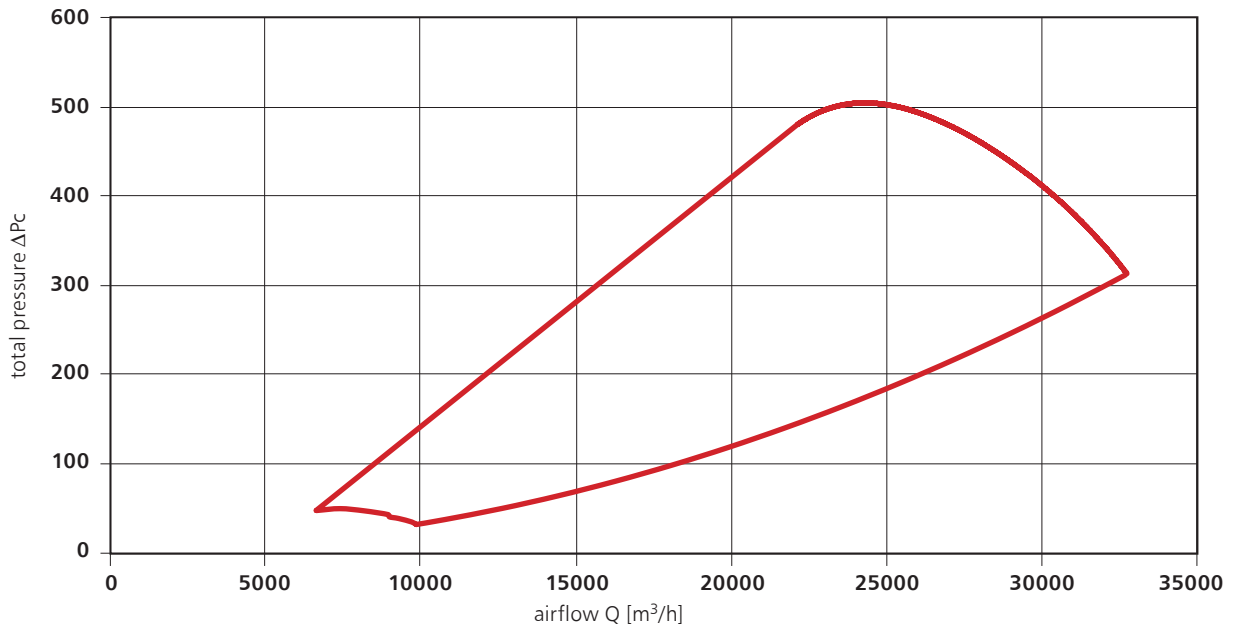

mcr EXi-F 63-1M unit fan

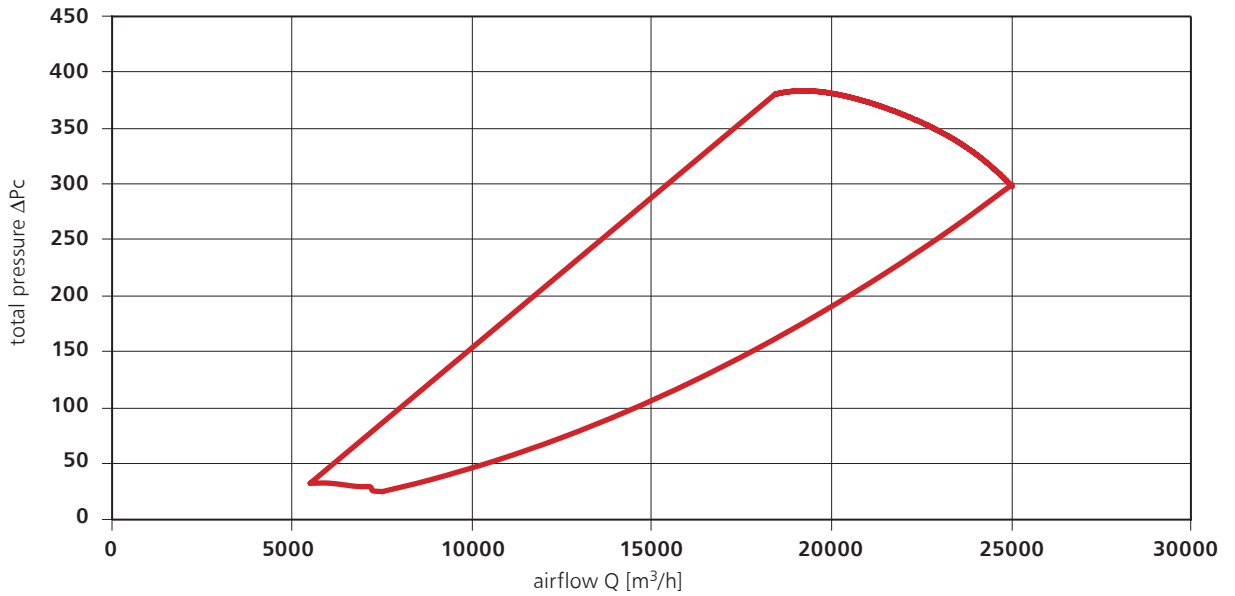

mcr EXi-F 63-2M unit fan

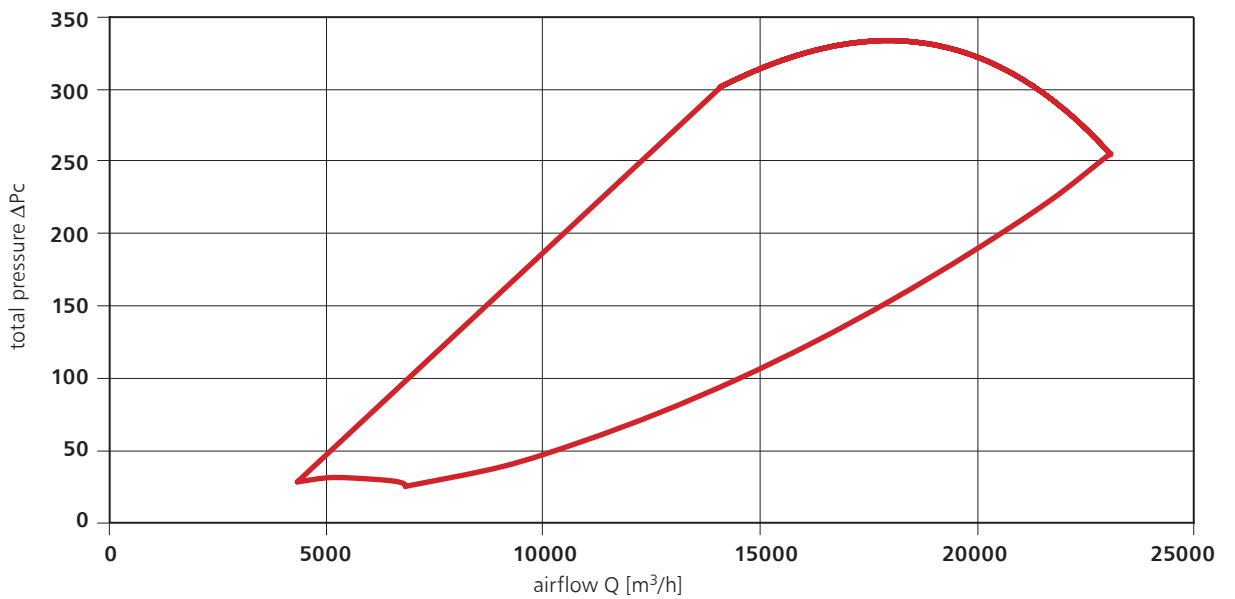

mcr EXi-F 56-1M unit fan

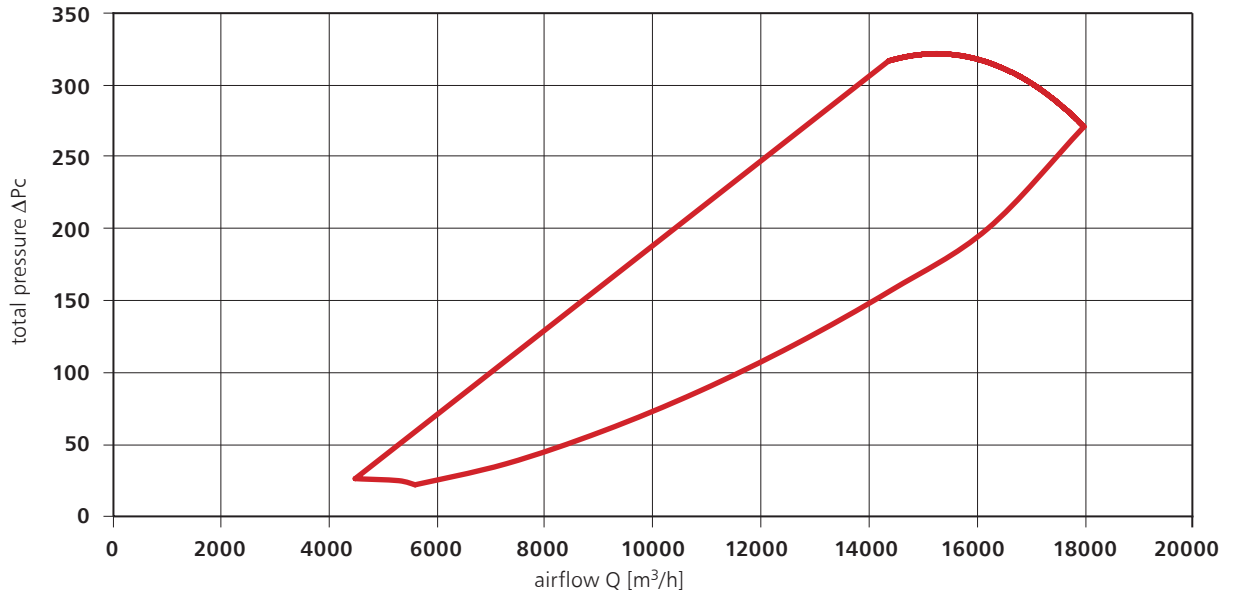

mcr EXi-F 50-1M unit fan

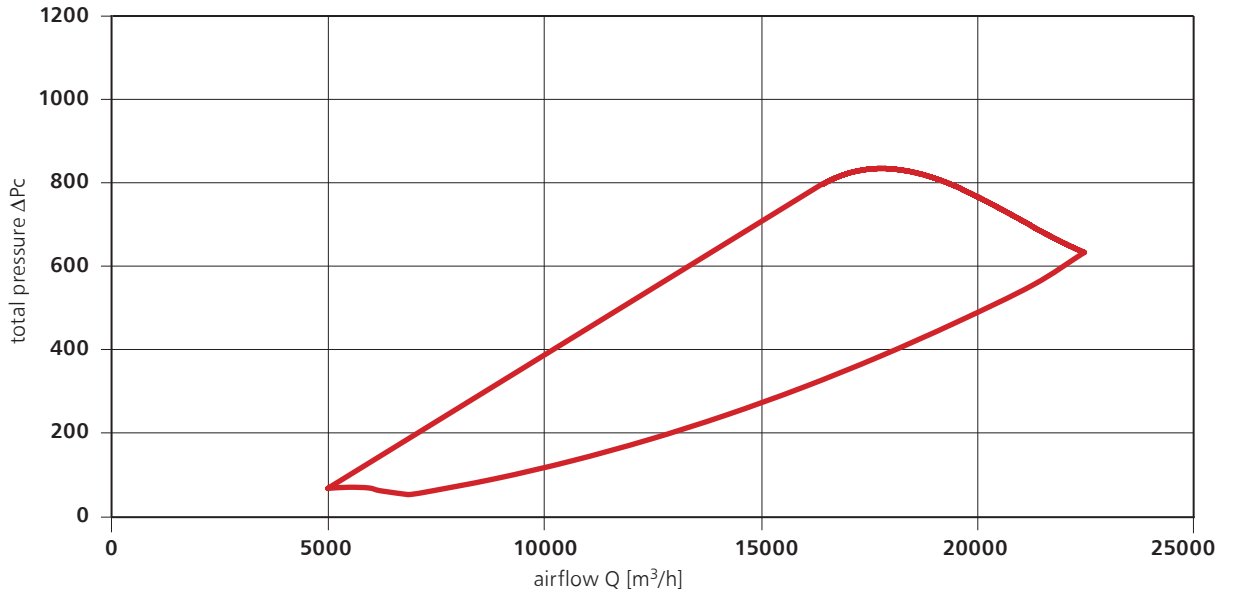

mcr EXi-F 100-1S unit fan

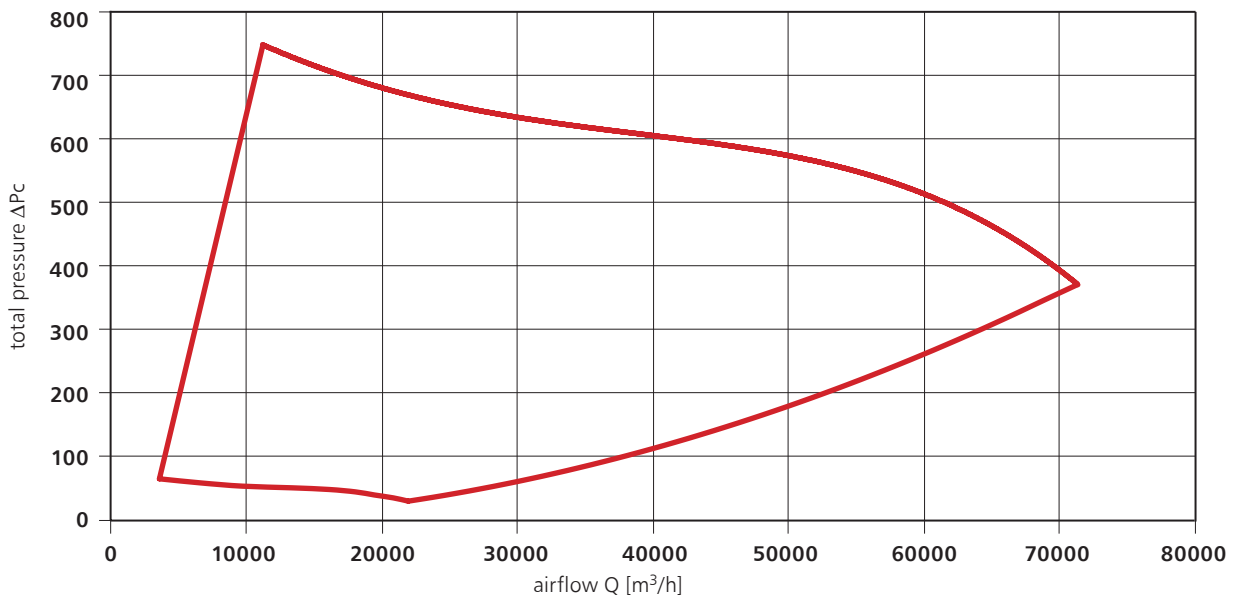

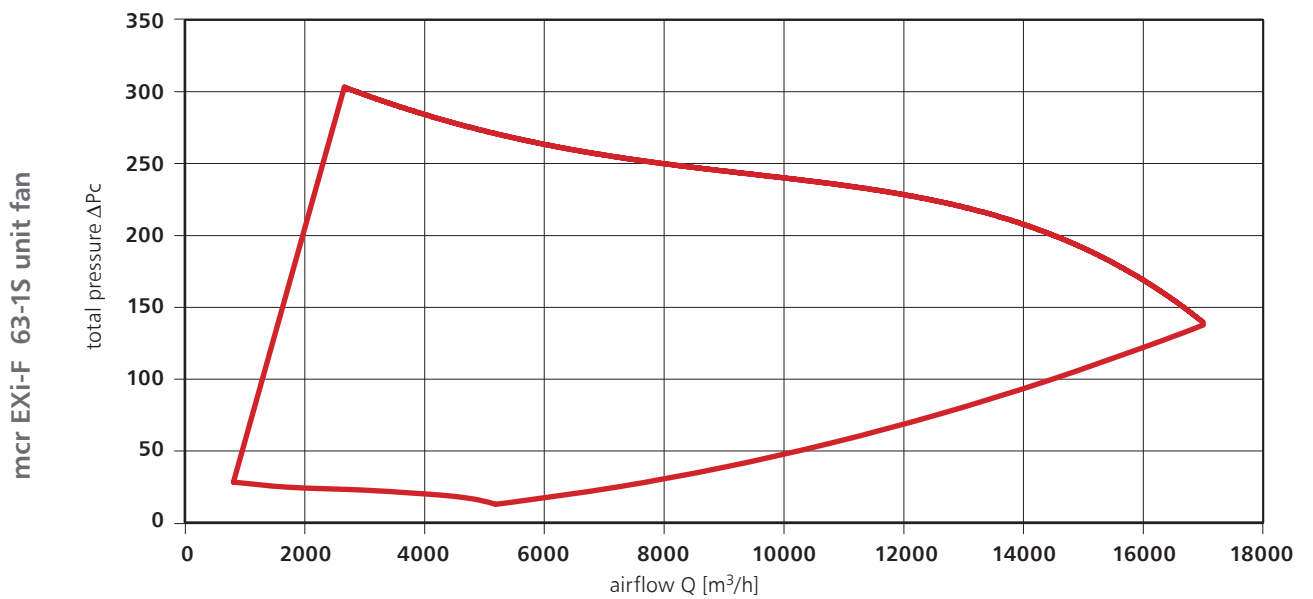
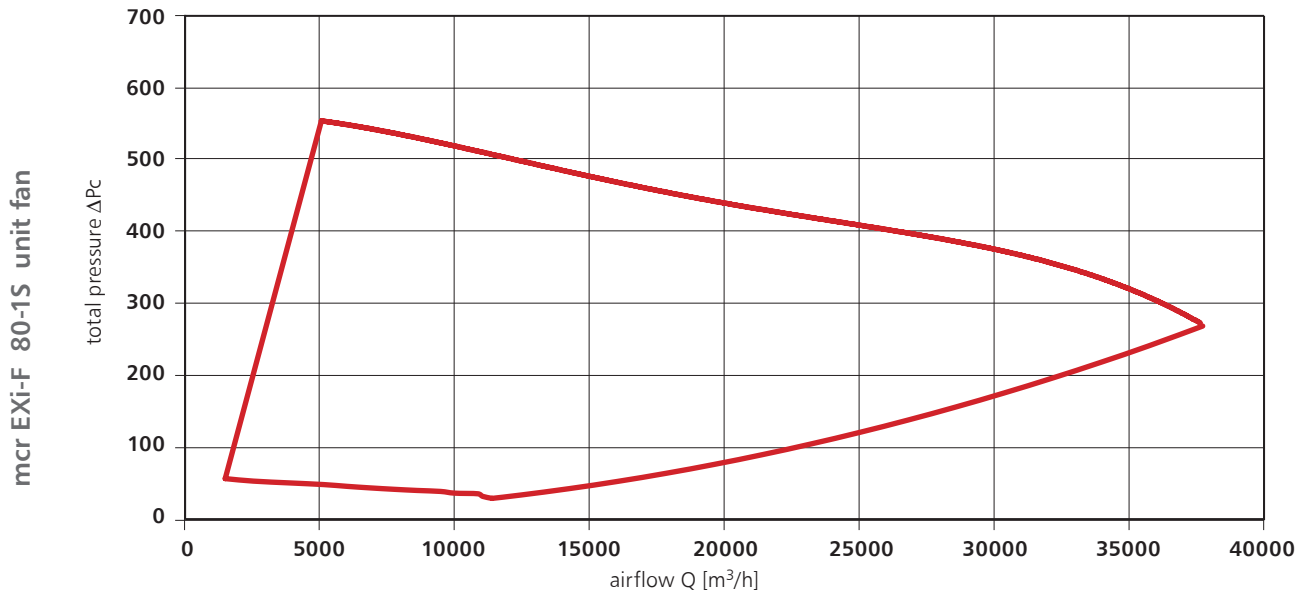
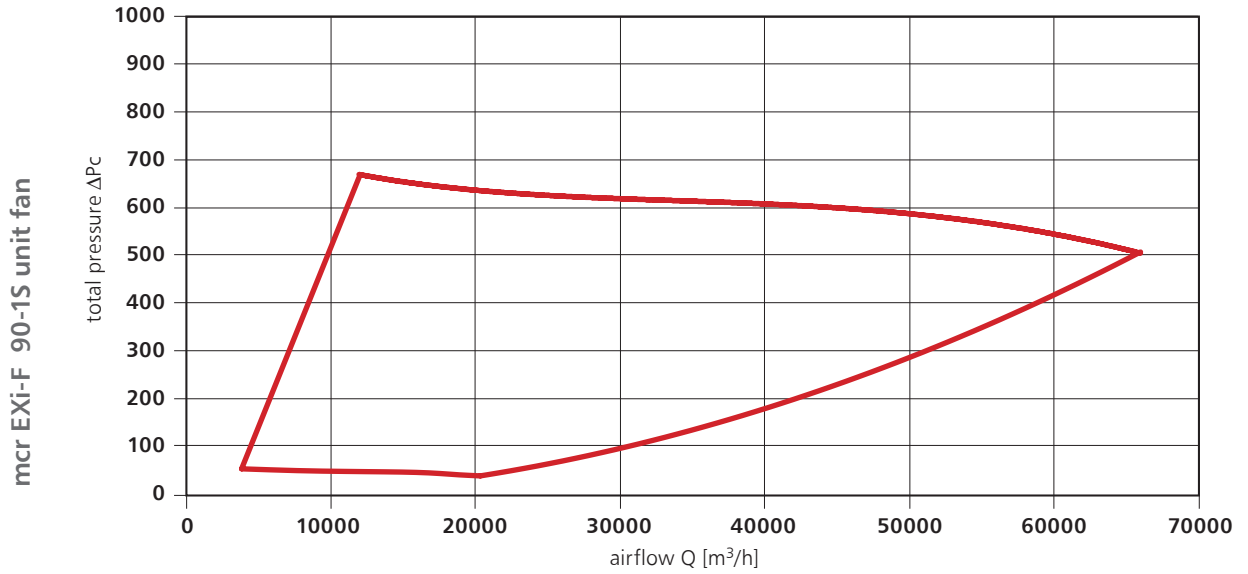

Basic hydraulic parameters of mcr EXi-F system's air supply units

system type	fan type	power [kW]	airflow minimum [m ³ /h]	airflow nominal [m ³ /h]
mcr EXi-F 100-1M	mcr Monsun BO 100/4	18,5	16800	60000
mcr EXi-F 90-1M	mcr Monsun BO 90/4	15	15000	55000
mcr EXi-F 80-1M	mcr Monsun BO 80/4	11	7000	40000
mcr EXi-F 71-1M	mcr Monsun BO 71/4	7,5	5000	30000
mcr EXi-F 63-1M	mcr Monsun BO 63/4	4	1500	19000
mcr EXi-F 63-2M	mcr Monsun BO 63/4	3	1500	16000
mcr EXi-F 56-1M	mcr Monsun BO 56/4	3	1500	16000
mcr EXi-F 50-1M	mcr Monsun BO 50/2	5,5	6000	17000
mcr EXi-F 100-1S	mcr Monsun E 100-4T-20	15	16400	63200
mcr EXi-F 90-1S	mcr Monsun E 90-4T-10	7,5	5000	35000
mcr EXi-F 80-1S	mcr Monsun E 80-4T-5,5	4	1500	19000
mcr EXi-F 63-1S	mcr Monsun E 63-4T-1,5	1,1	1300	9000

Note:

If the operating point of the air supply unit's fan does not comply with the characteristics presented above, please contact the "MERCOR" S.A. Fire Ventilation Export Department.

2.3.2. mcr Omega power and control unit



The mcr Omega power and control unit supplies power and handles the operation of the entire system. The device is adjusted to collaborate with analogue and digital pressure control modules and a frequency inverter. The control unit carries out the required control and command functions for the pressure differential system along with the temporary fan control function. Additionally the control unit may be used as a fire partition controller.

mcr Omega control unit is supplied by 3 x 400 V. The control unit is powered from switchgear bay for fire protection devices. The bay is either not subject to shut down with fireman's switch or is equipped with an SZR (Automatic Reserve Supply). The control unit may be fitted with an internal SZR.

Primary functions of the mcr Omega control unit (TZS Omega):

- power supply, control and command of operation of fans comprising air supply units for positive pressure generation accordingly to signal sent from the fire control panel,
- power supply, control and command of the air dampers (flow control and cut-off functions),
- power supply and handling of in-duct smoke detectors,
- power supply and handling of pressure converters,
- power supply and handling of auxiliary elements of the system.

Standard mcr Omega control unit features a steel housing fitted with a pair of doors at the front. The housing is made in conformity with the IP 54 class. Depending on its version, on the top or the bottom of the device is fitted with a cover equipped with glands for connecting electrical cables. The size of the system and the number of external devices to be powered and controlled determine the distribution and the number of the glands. The dimensions of the control unit vary between 800 x 600 x 300 mm and 1200 x 2000 x 300 mm, depending on the number of controlled devices and the complexity of performed operations and the "switching programme".

Depending on the size of the system, mcr Omega control unit comprises the following components:

- control and automatic system units, based on mcr MMS 2063 microprocessor monitoring and control modules,
- power supply unit (buffer PSU with batteries),
- frequency inverters,
- overcurrent protection and three-phase contactors,
- mcr ICR smart pressure regulator (compatible with mcr ICS pressure converters).

mcr Omega control unit works with fire control panels within the following procedures:

- receiving of the alarm signal from the fire control panel (CSP) initiating the fire programme (the so-called "hardwire" signal),
- sending feedback to the CSP fire control panel signalling damage to control unit (the so-called "hardwire" signal),
- confirming the execution of control procedure for connected devices to the fire control panel (the so-called "hardwire" signal).

All inputs and outputs of the control unit (all lines) are continuously monitored for interruption or short-circuit through EOL resistors. Control unit checks the time parameters of connected devices' functioning and provides control of continuity of fan's supply line in terms of interruption or a short circuit also during standby.

A visualisation panel is mounted on the door of the control unit with LED indicators informing of:

- power supply condition (green LED on - power supply OK),
- failure/damage (yellow LED off - the control unit is functioning properly),
- CSP fire control panel alarm (red LED off - no CSP alarm),
- "Reset" button (delete alarm) pressing for 5 seconds enables returning the control unit to initial operating mode (on standby). The button will function only if there is no alarm input from CSP.

Additionally, each control unit contains an internal "Test" button. When the test procedure is initiated, the control unit will carry out the alarm procedure recorded in its modules/controllers accordingly to the scenario of the fire. After the procedure is carried out, regardless of the outcome, the control unit will return its output to the initial status, enabling the external devices to be set to their standby for alarm mode.

Note:

According to the assumed operational topology, a single mcr Omega control unit supports by default a single smoke prevention system (air supply unit, additional elements and automatics).

Basic technical specifications of the mcr Omega control unit:

Basic supply voltage	400 V AC +10%...-15%, 50 Hz
Control unit's operating voltage	22.5 V...32 V AC (24 V at 200°C)
Backup power supply*	- backup power supply at the location - certified power supply for fire protection, e.g. mcr Omega
Control unit's monitoring input from the mcr MMS 2063 module (interruption and short-circuit detection, line continuity control)	24 V AC with optoelectronic separation (6 inputs for every mcr MMS 2063 module)
Control unit's control and supply outputs from the mcr MMS 2063 module	Io=4A, 250 V AC, 25 V DC (3 outputs for every mcr MMS 2063 module)
Maximum power consumption of a single mcr MMS 2063 module's actuators	20 A
Battery capacity	2.2 Ah - 20 Ah
Backup power supply runtime	72 h
Alarm signal arrangement	1 stage (2 nd degree)
Casing protection rating	IP 54
Environmental class	III
Operating temperature range	-5°C...+75°C
Relative humidity	90%
Housing material	powder-coated steel
Dimensions (width x height x depth)	series of types [mm]: 800x600x300, 800x800x300, 800x1000x300, 800x1200x300, 1000x600x300, 1000x800x300, 1000x1000x300, 1000x1200x300, 1200x1000x300, 1200x1200x300, 1200x2000x300
Programme of action	variable, depending on the requirements of the building's fire scenario

*applies to smoke control devices' and fire partitions' power supply and control, in case of which back-up power supply is legally required for correct operation.

2.3.3. pressure differential converters, pressure measurement points

The mcr EXi-F system may include:

- mcr ICS digital pressure differential converter,
- type 984M analogue pressure differential converter.

The protected pressurised area should be fitted with a minimum of one pressure converter. The type and the number of converters depend on the type of protected area and the design criteria. If the design is based on the Instruction [2] - the 20-80 Pa positive pressure criterion - it is advised to use two pressure converters located on the edge of the protected area.

2.3.3.1. mcr ICS digital pressure differential converter



The device measures the pressure difference within the protected area (staircases, lift shafts, protected lobbies, escape corridors). Two pressure tubes (included as accessories for the converter) should be connected to the converter. The results of the measurements are sent in real time to the mcr Omega control unit and its mcr ICR controller via digital interface; the controller, an integrated component of the control unit, controls the operations of air supply unit (via an inverter).

mcr ICR can be connected to as many as 24 mcr ICS digital pressure differential converters. The components of the system communicate via a mcr BUS, which combines high bandwidth with high level of security. mcr BUS is a multi-master bus, meaning the data can be sent at any time by any device connected to the bus. This allows particular converters to immediately report any damage or alarm signal detection to the controller.

The elements are connected in the loop topology, ensuring proper functioning of the entire system in case of singular damage to communication cables. The continuity of the line is constantly monitored. The pressure converters send to the controller periodic information on their status, facilitating continuous control over the system status and detecting damages, such as:

- line interruption,
- mcr ICS digital pressure converter removal or damage,
- alarm input interruption at mcr ICS,
- mcr ICS digital pressure sensor damage.

mcr ICS technical specification

Power supply	24 V, AC/DC
Protection	0.5 A internal fuse
Operating temperature	-25°C...+55°C
Casing protection rating	IP 44
Installation	to a flat surface, using 2 x 6 mm screws
Cable grommets	4 x PG11 glands with gaskets
Electric connection	1.5 mm ² maximum diameter of cable cords, maximum 1 cord per 1 terminal
Pressure connection	pressure tube connectors; 8 mm diameter spigots on the casing
Output	differential interface, distributed system, RS485 galvanically isolated controller
Sensor range	pressure 0-500 Pa
Maximum positive pressure	100 kPa
Measurement error	± 1.5%
Dimensions of the casing	110x110x65 mm

2.3.3.2. 984M analogue pressure differential converter



984M pressure differential converter measures the pressure difference within the protected area (staircases, lift shafts, protected lobbies, escape corridors). The results of the measurements are sent in real time using an analogue signal to the mcr Omega power and control unit. The 984M series converters are set for 0-100 Pa pressure and 0-10 V input signal ranges.

984M pressure converter technical specification

Power supply	24 V, AC/DC
Operating temperature	0...50°C
Linearity and hysteresis error	≤ ±1% F.S.
Long-term stability	≤ ±0.5% % F.S./year
Repeatability	≤ ±0.2% F.S.
Permitted humidity	0...95% relative humidity, non-condensed
Response time	10 ms
Pressure connection	6 mm diameter external spigots
Electrical connection	screw terminal connector 1.5 mm ²
Dimensions of the casing	ø 85x58 mm
Weight	130 g
Protection rating	IP 00 - without casing
	IP 54 - with casing

2.3.3.3. measurement points for pressure converters

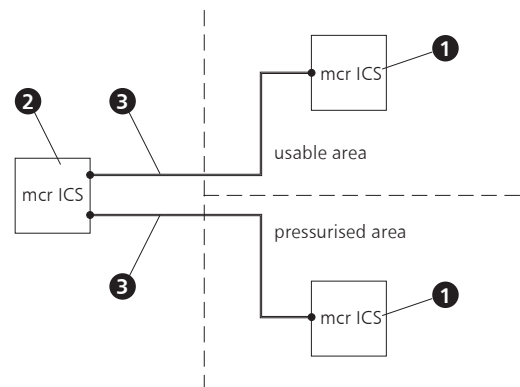

Two pressure tubes [3] should be connected to pressure converters [2]. One of the tubes is located in pressurised area, while the other is in usable area. Pressure measurement points [1] should be attached at the ends of the tubes.

Dimensions of the casing: 50x50x40 mm

Pressure tube connector: ø8 mm socket

2.3.4. U2 intake terminal reconnecting system

If the air intakes for the mcr EXi-F system are located on the roof level, two intakes are necessary. They should be placed at a distance from one another and facing different directions, in order to prevent them from being both directly on the leeward side of the same source of smoke. Each of the intakes should have the capacity to provide the total quantity of air necessary for the system to operate correctly. Each of the intakes should be protected by an independent system of cut-off air dampers ensuring smoke dispersion control, so that if one air damper closes due to contamination of air with smoke, the other intake provides an uninterrupted supply of air required by the system. Smoke detection is ensured by smoke detectors located in front of each air dampers. The tasks listed above are carried out by the so-called intake terminal reconnecting system, which uses two cut-off air dampers powered by counteracting Belimo B(L)E actuators.

Basic dimensions of air dampers used in twin intake terminal reconnecting system

system type	air damper			~weight [kg]
	a [mm]	b [mm]	c [mm]	
mcr EXi-F 100-1M	1300	1300	115	23
mcr EXi-F 90-1M	1300	1300	115	23
mcr EXi-F 80-1M	1200	1200	115	22
mcr EXi-F 71-1M	1100	1100	115	18
mcr EXi-F 63-1M	800	800	115	13
mcr EXi-F 63-2M	800	800	115	13
mcr EXi-F 56-1M	800	800	115	13
mcr EXi-F 50-1M	800	800	115	13
mcr EXi-F 100-1S	1100	1100	115	18
mcr EXi-F 90-1S	1100	1100	115	18
mcr EXi-F 80-1S	900	900	115	14
mcr EXi-F 63-1S	700	700	115	10

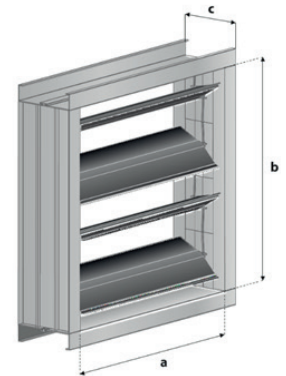

Example of mcr EXi-F system air supply set with twin intake terminal reconnecting system

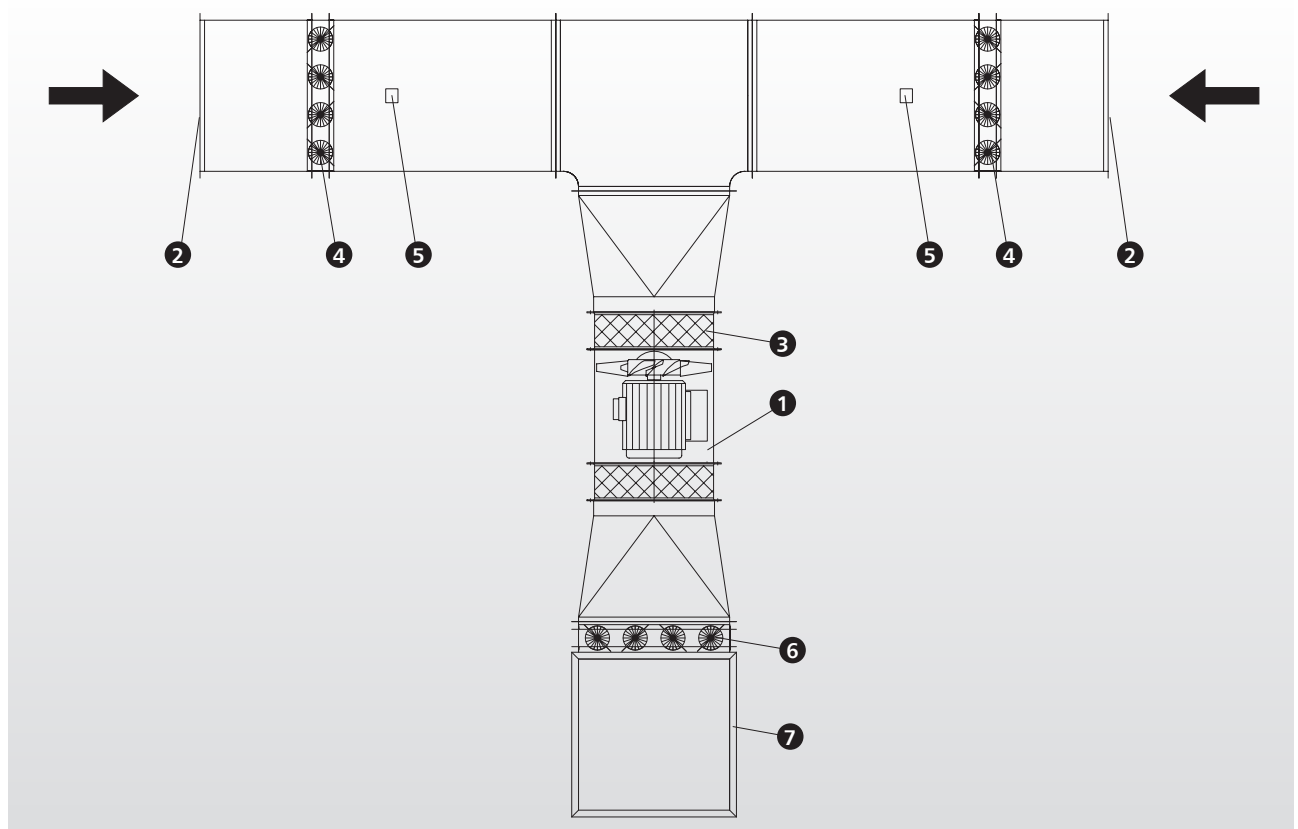

- 1. air supply unit
- 2. inlet
- 3. flexible connection
- 4. air dampers with actuators in twin intake terminal reconnecting system
- 5. in-duct smoke detectors
- 6. cut-off air damper
- 7. ventilation duct

2.3.5. UG-3-A4 in-duct smoke detector



UG-3-A4 smoke detector is used for smoke detection in:

- air supply units' intake ducts,
- U2 intake terminal reconnecting system.

Upon detecting smoke at the inlets of air supply units of the protected area, the device automatically shuts down the system or, in a twin intake terminal reconnecting system, controls the operations of the air dampers, so as to secure the suction of a smoke-free air.

There are two versions of the detector: one for indoor operations, and the other, equipped with a UG Cover casing, for outdoors.

Basic dimensions of the detector

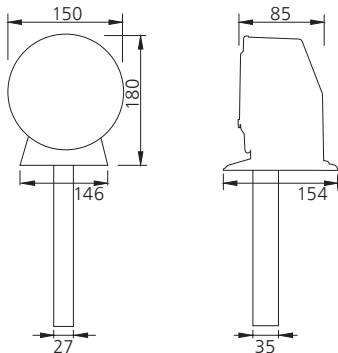

Casing for outdoor use

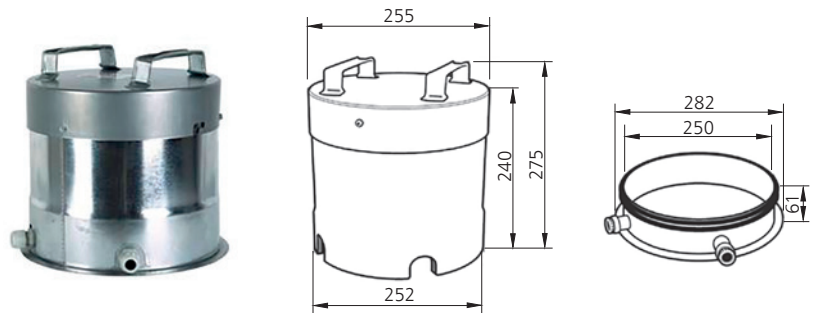

2.3.6. PSR manual control panel

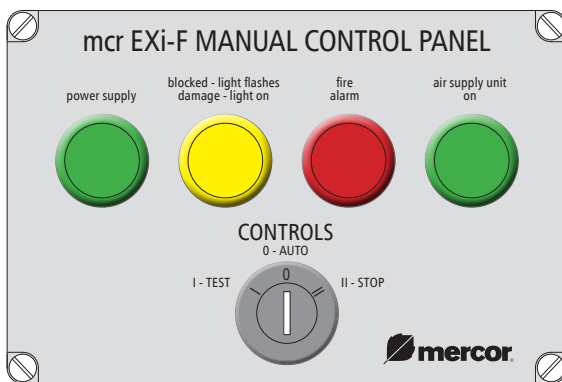

PSR manual control panel enables remote manual initiation or shut-down of mcr EXi-F system, e.g. by the commander of the firefighting operation. The panel should be installed in locations easily accessible for rescuers. Additionally, the PSR panel signals the following statuses of the mcr Omega control unit:

- power supply OK,
- system damage,
- alarm operation mode,
- system manually blocked,
- air supply unit ON.

Dimensions of the panel: 200 x 120 x 80 mm.

2.3.7. mcr PL, mcr PLD bleed dampers and overpressure-relief dampers

Overpressure-relief dampers may be used as an additional air release for the mcr EXi-F system in situations when it is difficult to secure the necessary operating parameters for the system.

Overpressure-relief dampers are normally closed. Once the pressure in the protected zone exceeds the design value, they open ensuring the equalisation of pressures. After the pressure in the protected zone is reduced, they return to their initial status and close. The mechanical construction of the dampers enables a response time of less than 1 second. The dampers can operate in a pressure range of 20-80 Pa.

mcr PL and mcr PLD dampers may be fitted with cut-off air dampers controlled from the mcr Omega control unit in accordance with the assumed system's actions scenario. When on standby the air dampers remain closed. They are equipped with Belimo spring return actuators. When needed, the air dampers open, enabling overpressure-relief dampers to operate.

The dampers can also be fitted with SP anti-icing system.

2.3.7.1. mcr PL wall and duct damper

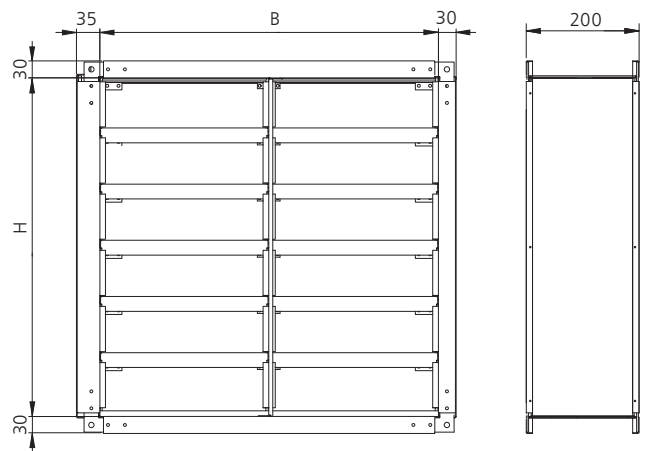

Basic dimensions and airflow of the mcr PL overpressure-relief damper

height H [mm]	width B [mm]								
	500	600	700	800	900	1000	1100	1200	1300
500	4050	4880	5700	6500	7300	8150	9000	9800	10600
600	4880	5860	6800	7800	8800	9800	10800	11800	12700
700	5700	6800	8000	9100	10300	11400	12500	13700	14800
800	6500	7800	9100	10500	11700	13000	14350	15600	16900
900	7300	8800	10300	11700	13200	14700	16100	17600	19000
1000	8150	9800	11400	13000	14700	16300	17900	19500	21150
1100	9000	10800	12500	14350	16100	17900	19700	21500	23300
1200	9800	11800	13700	15600	17600	19500	21500	23500	25400
1300	10600	12700	14800	16900	19000	21150	23300	25400	27500

Maximum airflow [m³/h] calculated for maintaining 50 Pa pressure differential.

2.3.7.2. mcr PLD roof damper

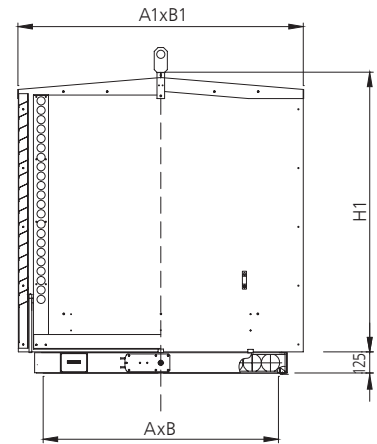

mcr PLD damper basic technical specification

dimensions of the base within the opening	total dimensions	maximum release for 50 Pa	~weight
AxB [mm]	A1xB1xH1 [mm]	[m ³ /h]	[kg]
1300x1300	1580x1490x1550	22 000	245
800x800	1170x1080x1100	10 000	100

Example of the mcr PLD damper configuration with a roof base

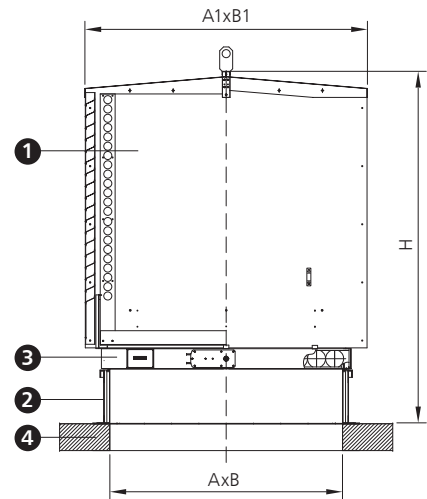

- 1. mcr PLD roof damper
- 2. roof mounting base*
- 3. air damper
- 4. roof

* the damper may be delivered with a dedicated roof mounting base

mcr PLD damper set basic technical specifications

dimensions of the base within the opening	total dimensions	air damper	roof mounting base	maximum release for 50 Pa	~weight
AxB [mm]	A1xB1xH [mm]	thickness [mm]	height [mm]	[m ³ /h]	[kg]
1300x1300	1580x1490x1975	125	300	22 000	315
800x800	1170x1080x1525	125	300	10 000	129

2.3.7.3. mcr LAM louvre damper

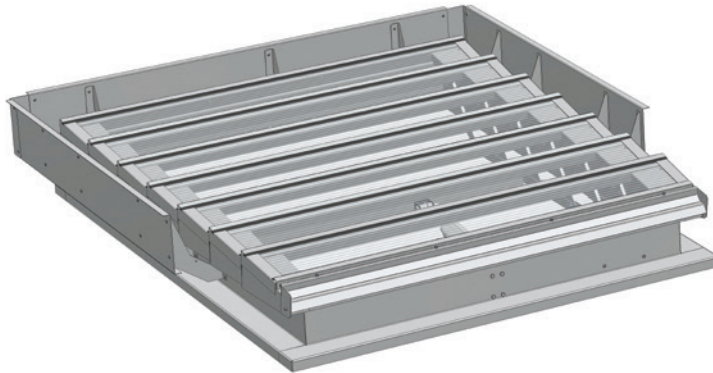

When integrated with the mcr EXi-F system a mcr LAM louvre damper:

- supplies fresh air to the interior of the building,
- evacuates air and smoke from the building,
- serves as an air inlet for an air supply unit with a vertical air intake,
- serves as an additional unseal of protected area,
- serves as an air inlet on sloped roofs.

The drainage of the mcr LAM louvre dampers is designed to facilitate high parameters of water protection regardless of where the device is located (from flat roofs, through any type of sloped roof, to façades and walls).

The declared classes and characteristics of the mcr LAM damper (such as snow load class up to SL1300, wind load class up to WL4000) guarantee operational reliability in adverse weather conditions.

mcr LAM louvre dampers are perfectly suitable for sloped roofs where it is impossible to install a regular air inlet or outlet.

Operational reliability of the damper – 10 000 cycles of openings and closures to ventilating position. The damper opens to a working position in maximum 60 seconds.

mcr LAM louvre damper basic dimensions

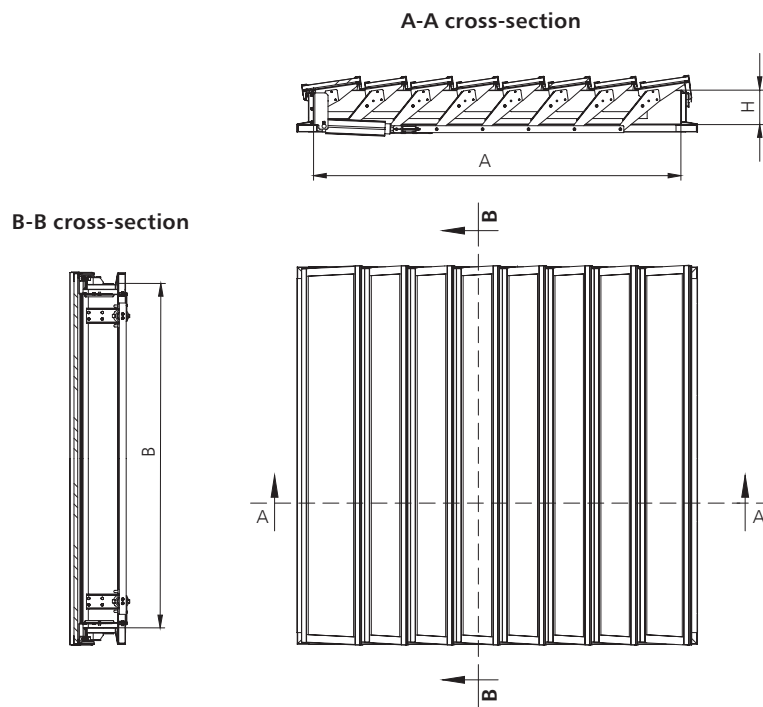

mcr LAM louvre dampers are available in the following sizes:

- dimension A from 800 to 3800 mm (gradation every 200 mm),
- dimension B from 500 to 2500 mm (gradation every 100 mm),
- standard height of the damper base H from 150 to 250 mm.

2.3.8. mcr RPC unseal of protected area (optional)

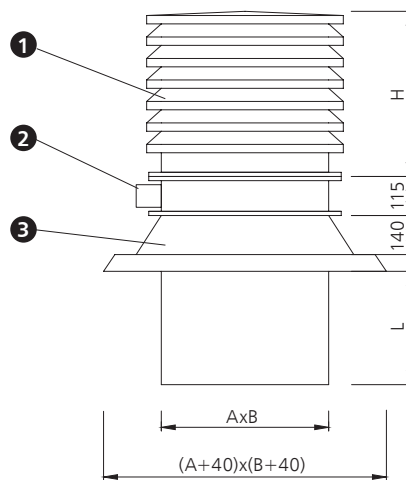

- 1. roof exhaust
- 2. air damper with BFN/BF actuator
- 3. roof mounting base

The mcr RPC unseal of the protected area is designed for use in sealed, pressurised areas. mcr RPC unseal minimises the pressure variations within the protected area caused by closing doors during the evacuation. mcr RPC comprises the following components: roof exhaust, multi-blade air damper, and a roof mounting base.

mcr RPC unseal of protected area basic dimensions

size	A [mm]	B [mm]	H [mm]	L [mm]
600x600	600	600	485	1000 (standard)
800x800	800	800	595	1000 (standard)

2.3.9. mcr WPS external signalling panel

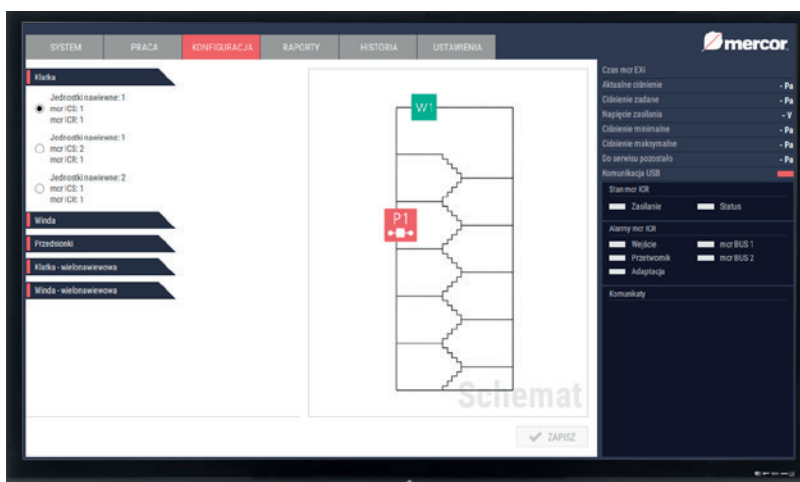

mcr WPS external signalling panel is an additional element of the system. It enables remote monitoring of operations of the system and its components. The panel consists of a touch screen placed in a casing, with created individually visualisation, the data presentation and the graphic design.

mcr WPS should be placed in a room accessible for rescue units, close to the manual control panel (PSR).

2.4. system components installation

The elements of the system are delivered to the site separately. The method of installation depends on the configuration of the system, as well as design requirements and the requirements of the building. The installation should be carried out in compliance with the provisions of the operation and maintenance manual and in accordance with the local building rules.

2.4.1. solution examples: air supply units in cylindrical housings

Single-point air supply to a staircase with a roof-mounted air supply unit.

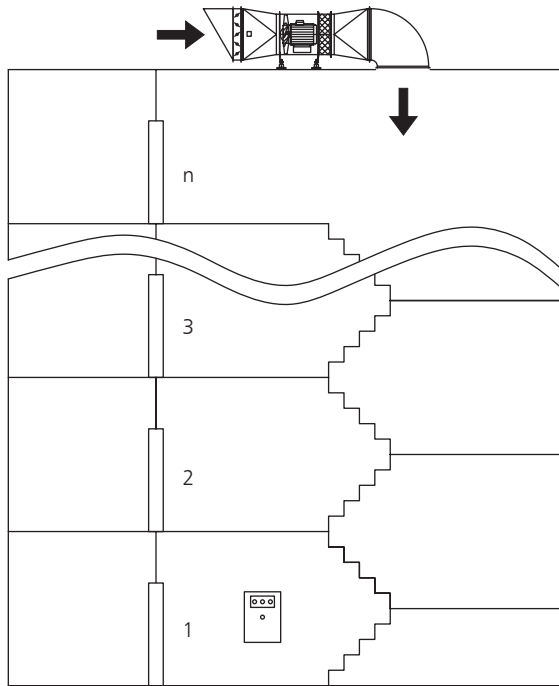

Two-point air supply to a staircase with air supply units located on the roof and in the building.

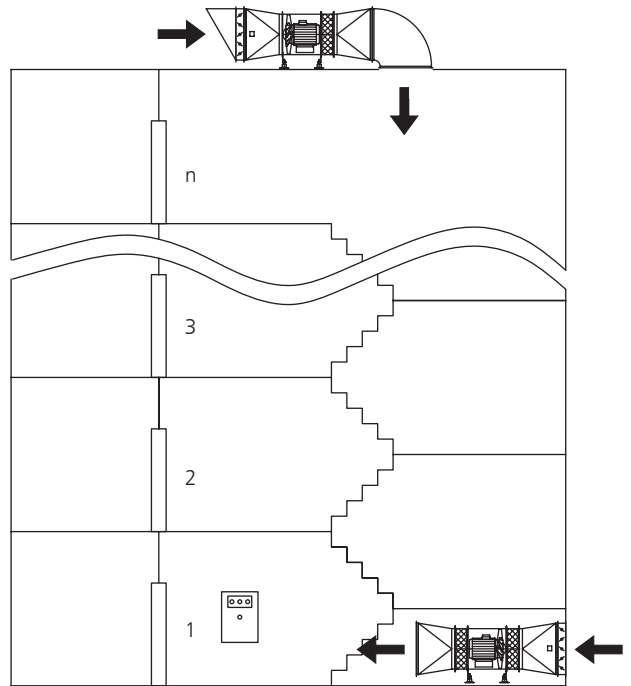

Multi-point air supply to the staircase with a roof-mounted air supply unit.

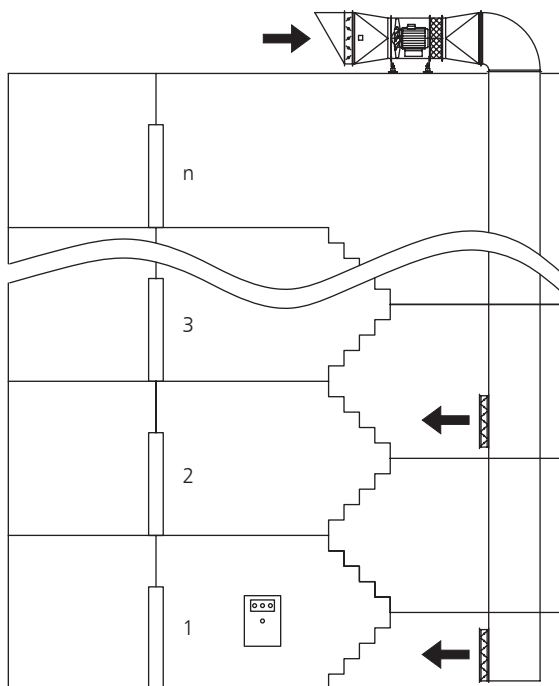

Single-point air supply to the lift shaft with a roof-mounted air supply unit.

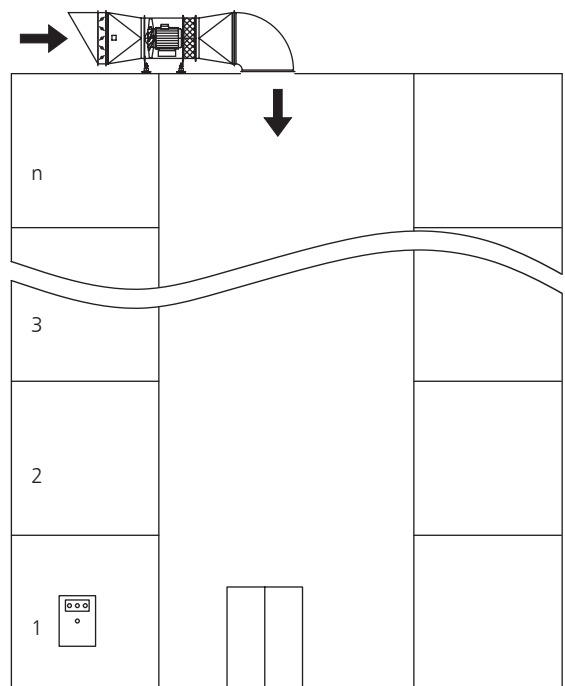

Two-point air supply to the lift shaft with air supply units located on the roof and in the building.

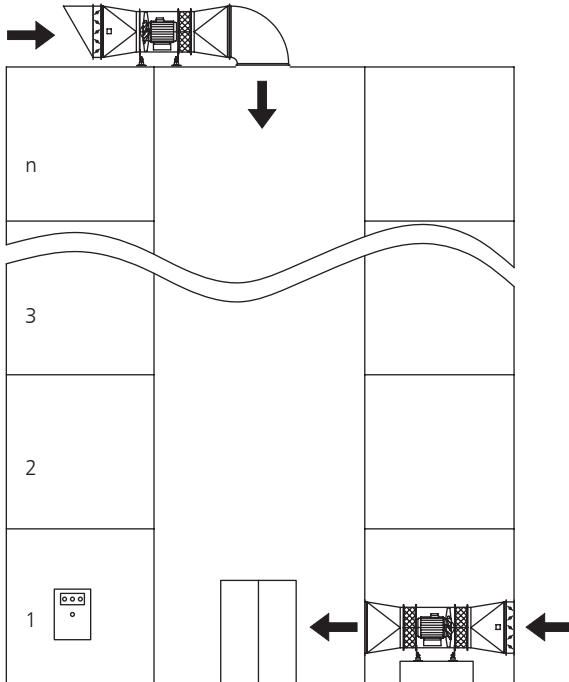

2.4.2. solution examples: air supply units in box housings

Single-point air supply to the staircase with an air supply unit located on the roof.

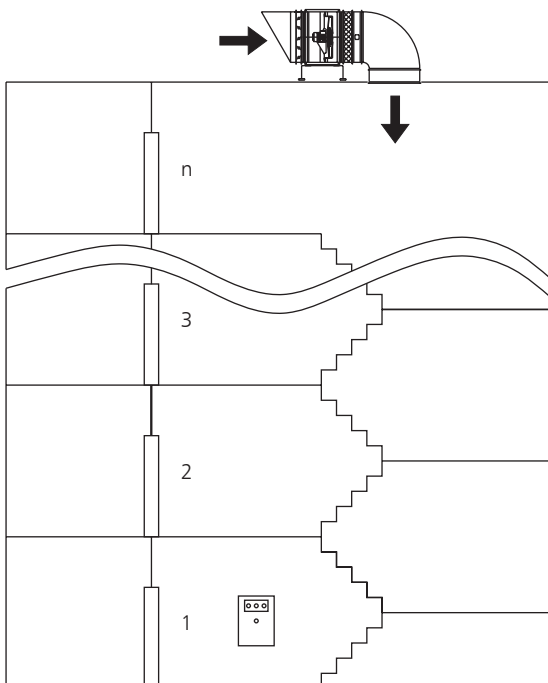

Two-point air supply to the staircase with a vertical air supply unit located on the roof and a wall-mounted air supply unit located inside or outside of the building.

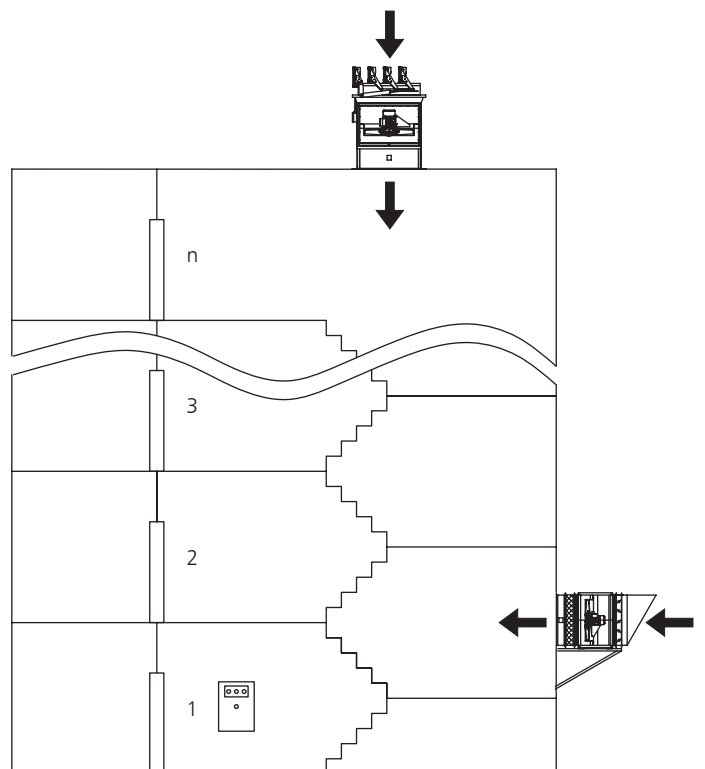

Multi-point air supply to the staircase with a roof-mounted air supply unit.

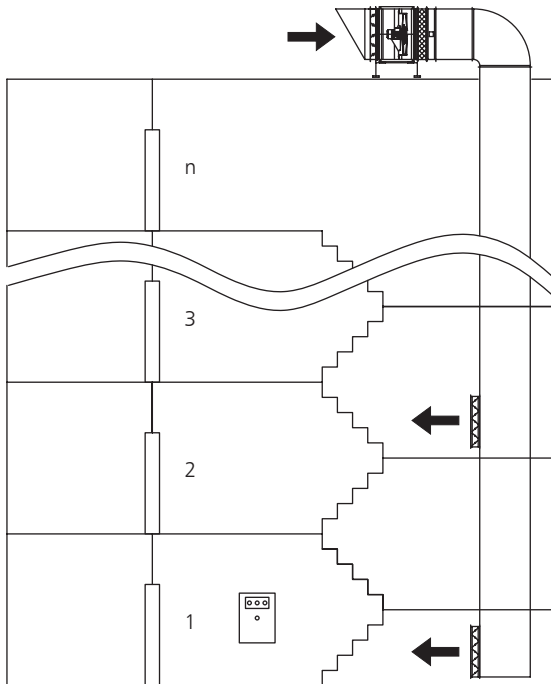

Single-point air supply to the lift shaft with a roof-mounted air supply unit.

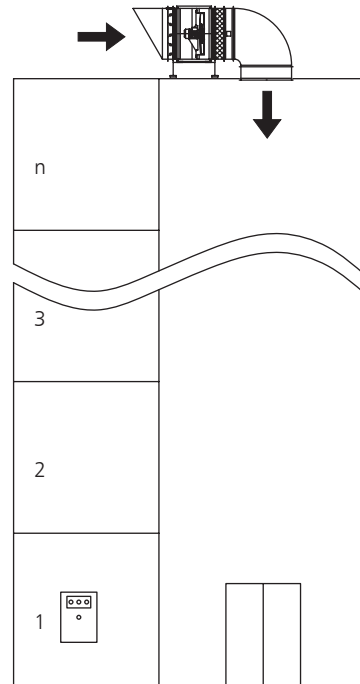

Two-point air supply to the lift shaft with an air supply unit located on the roof and a wall-mounted air supply unit located outside or inside the building.

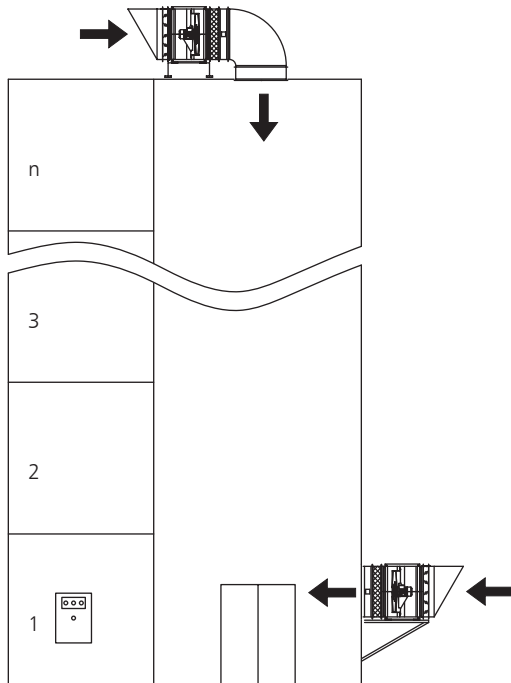

2.4.3. air supply units

Air supply units for the mcr EXi-F system offer full flexibility in terms of configuration and installation. In the standard arrangement they are delivered with an inlet and a cut-off air damper on the suction side.

Air supply units with cylindrical fan housing for the mcr EXi-F system use mounting feet equipped with shock absorbers. On the discharge side the unit is connected to the ductwork with a flexible connection.

Air supply units with box fan housing for the mcr EXi-F system are mounted directly onto the structure. Fan's mounting element is screwed onto the structure, with anti-vibration pads in between.

Flexible connections of air supply units prevent the transmission of the vibrations from the fan to the ductwork, acting as vibration compensators.

When installed vertically on a roof, air supply unit is mounted on a base/pedestal, while its discharge side is connected to e.g. air supply system. The suction side of the unit is protected against weather conditions with a mcr LAM louvre damper. The declared classes and characteristics of the mcr LAM damper (such as snow load class up to SL1300, wind load class up to WL1500) guarantee dependability in adverse weather conditions.

When mounted vertically inside a building, the unit is mounted using a support structure and connected, accordingly to design requirements, to e.g. air supply system.

mcr EXi-F system air supply units are fitted with actuator-powered multi-blade air dampers. The rotary mechanism consists either of gears and bearings or steel tie rods. The air dampers are powered by Belimo electric actuators.

Example of a roof-mounted, horizontally-oriented air supply unit for mcr EXi-F system

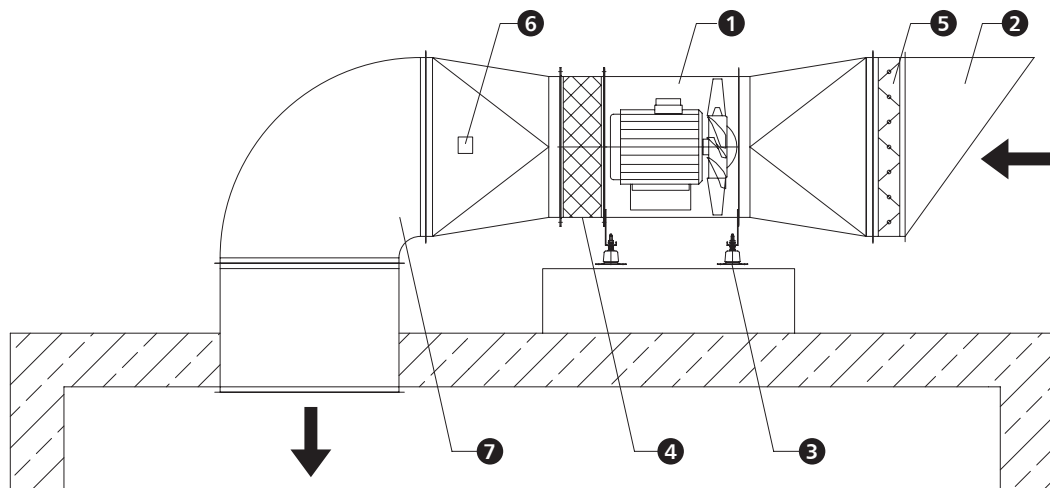

- 1. fan in box or cylindrical housing
- 2. air inlet with a net
- 3. shock absorber
- 4. flexible connection
- 5. air damper with actuator
- 6. in-duct smoke detector
- 7. ventilation ductwork

Example of a duct-mounted, horizontally-oriented air supply unit for mcr EXi-F system

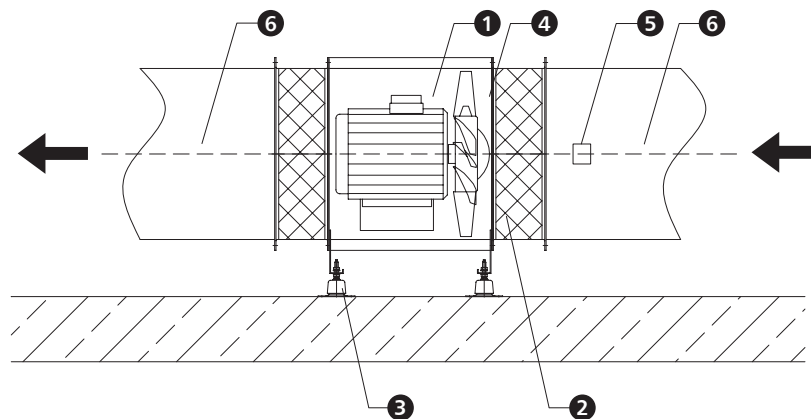

- 1. fan in cylindrical housing
- 2. flexible connection
- 3. shock absorber
- 4. soundproof housing (optional)
- 5. in-duct smoke detector
- 6. ventilation duct

Example of a wall-mounted indoor air supply unit for mcr EXi-F system

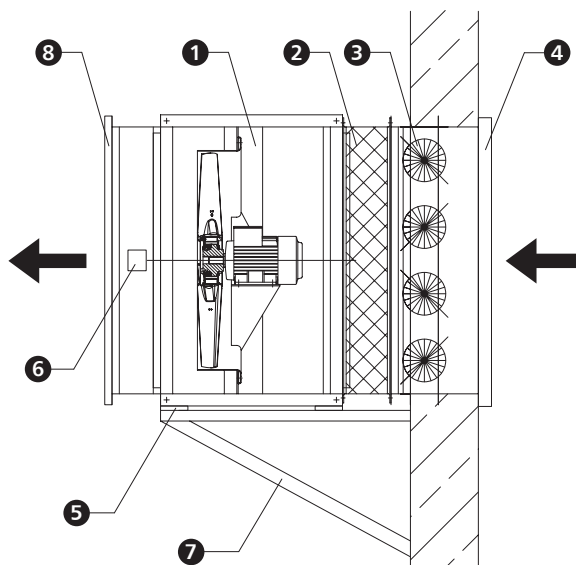

1. fan in box or cylindrical housing
2. flexible connection
3. multi-blade air damper with actuator
4. air inlet with a net
5. anti-vibration pad or shock absorbers
6. in-duct smoke detector
7. support structure
8. protecting net

Example of a wall-mounted outdoor air supply unit for mcr EXi-F system

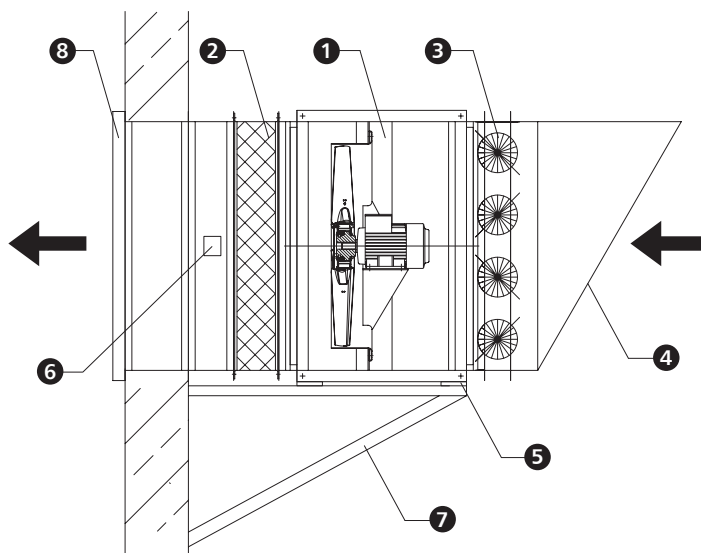

1. fan in box or cylindrical housing
2. flexible connection
3. multi-blade air damper with actuator
4. air inlet with a net
5. anti-vibration pad or shock absorbers
6. in-duct smoke detector
7. support structure
8. protecting net

Example of a roof-mounted air supply unit for mcr EXi-F system with vertical air intake with a mcr LAM damper

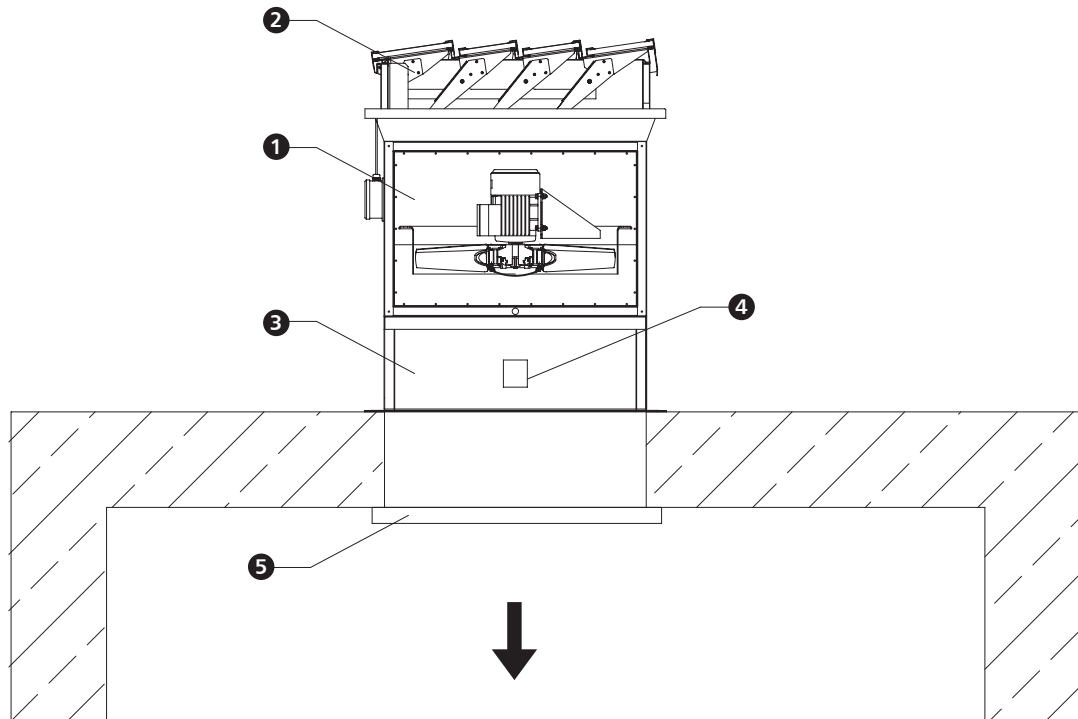

- 1. fan in box housing
- 2. mcr LAM louvre damper
- 3. roof mounting base
- 4. in-duct smoke detector
- 5. protecting net

Example of an air supply unit for mcr EXi-F system with sloped roof inlet version with a mcr LAM damper

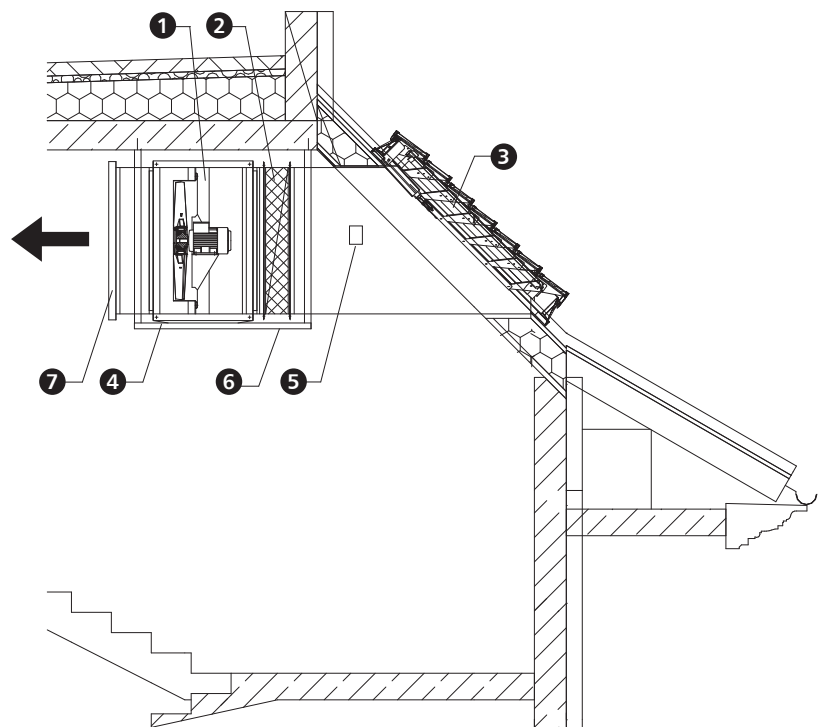

- 1. fan in box or cylindrical housing
- 2. flexible connection
- 3. mcr LAM louvre damper as an inlet
- 4. anti-vibration pad or shock absorbers
- 5. in-duct smoke detector
- 6. support structure
- 7. protecting net

Example of a roof-mounted air supply unit for mcr EXi-F system with twin air inlet (U2 intake terminal reconnecting system)

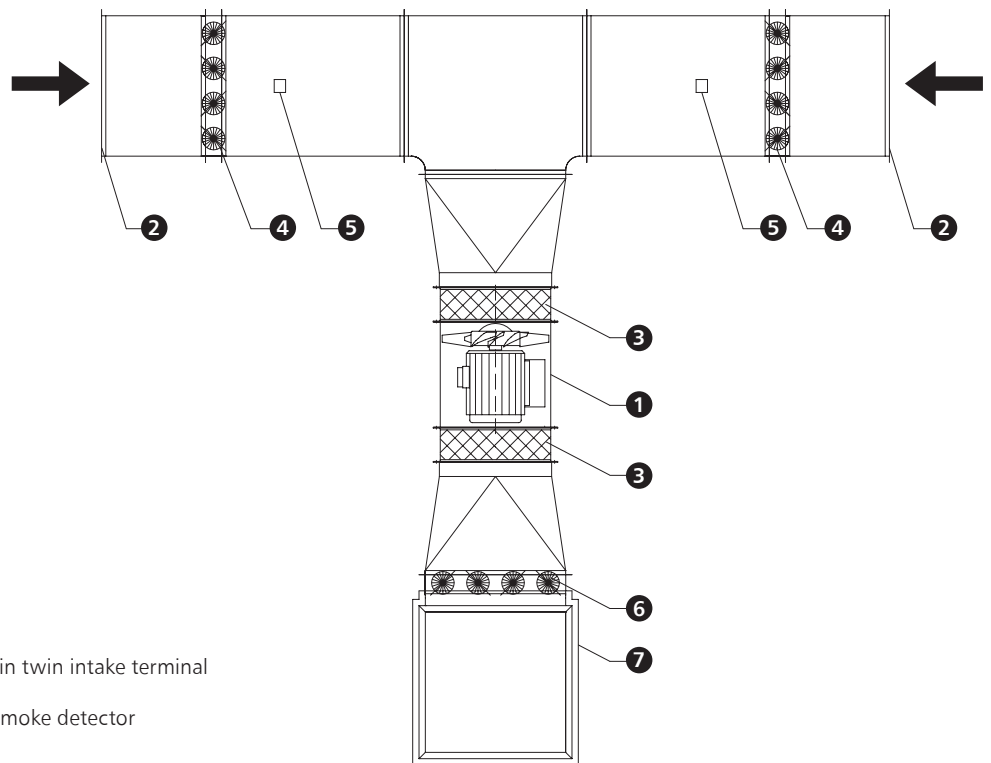

- 1. air supply unit fan
- 2. inlet
- 3. flexible connection
- 4. air dampers with actuators in twin intake terminal reconnecting system
- 5. outdoor variant of in-duct smoke detector
- 6. cut-off air damper
- 7. ventilation duct

Example of roof-mounted air supply unit for mcr EXi-F system with backup unit

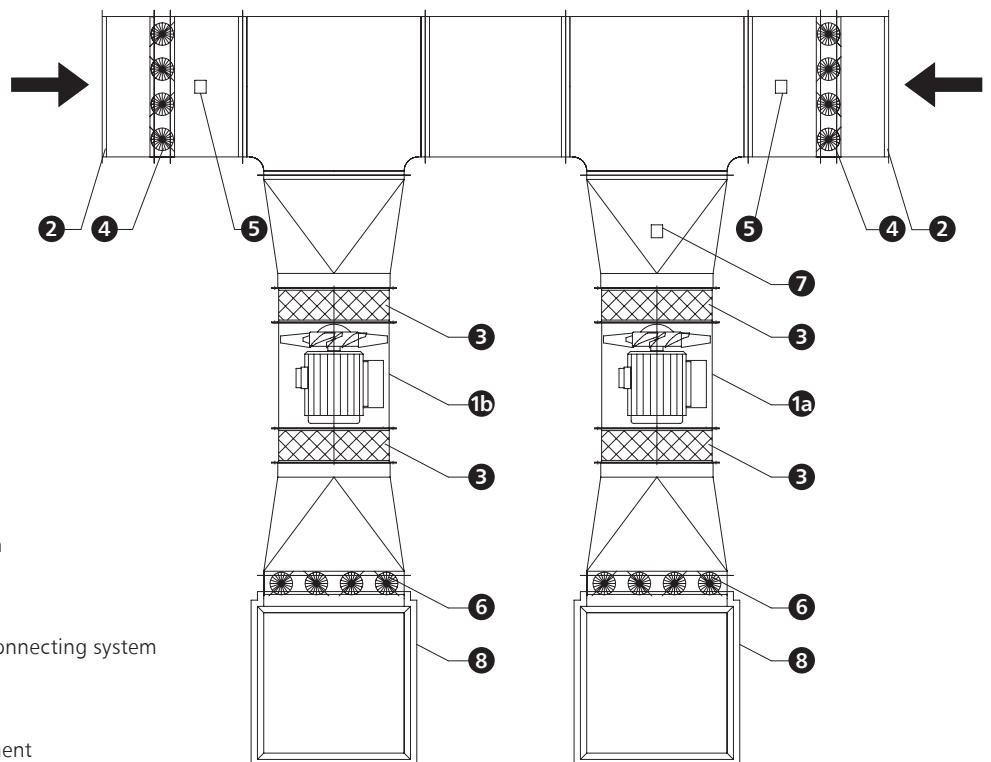

- 1a. air supply unit primary fan
- 1b. air supply unit back-up fan
- 2. inlet
- 3. flexible connections
- 4. air dampers with actuators in twin intake terminal reconnecting system
- 5. in-duct smoke detector in outdoor variant
- 6. cut-off air damper
- 7. pressure switch: measurement of pressure in the duct
- 8. ventilation duct

2.4.4. mcr Omega power and control unit

The control unit is mounted on the wall or on the floor, depending on the variant and the size of the device. The control unit should be fastened with min. M10 anchors. Securing space for maintenance procedures and proper air circulation should be taken into consideration during installation. Electrical cables should be inserted into the device through electric glands. Electrical connections should be carried out as presented in the diagram delivered together with the device.

2.4.5. pressure differential converters, measurement points

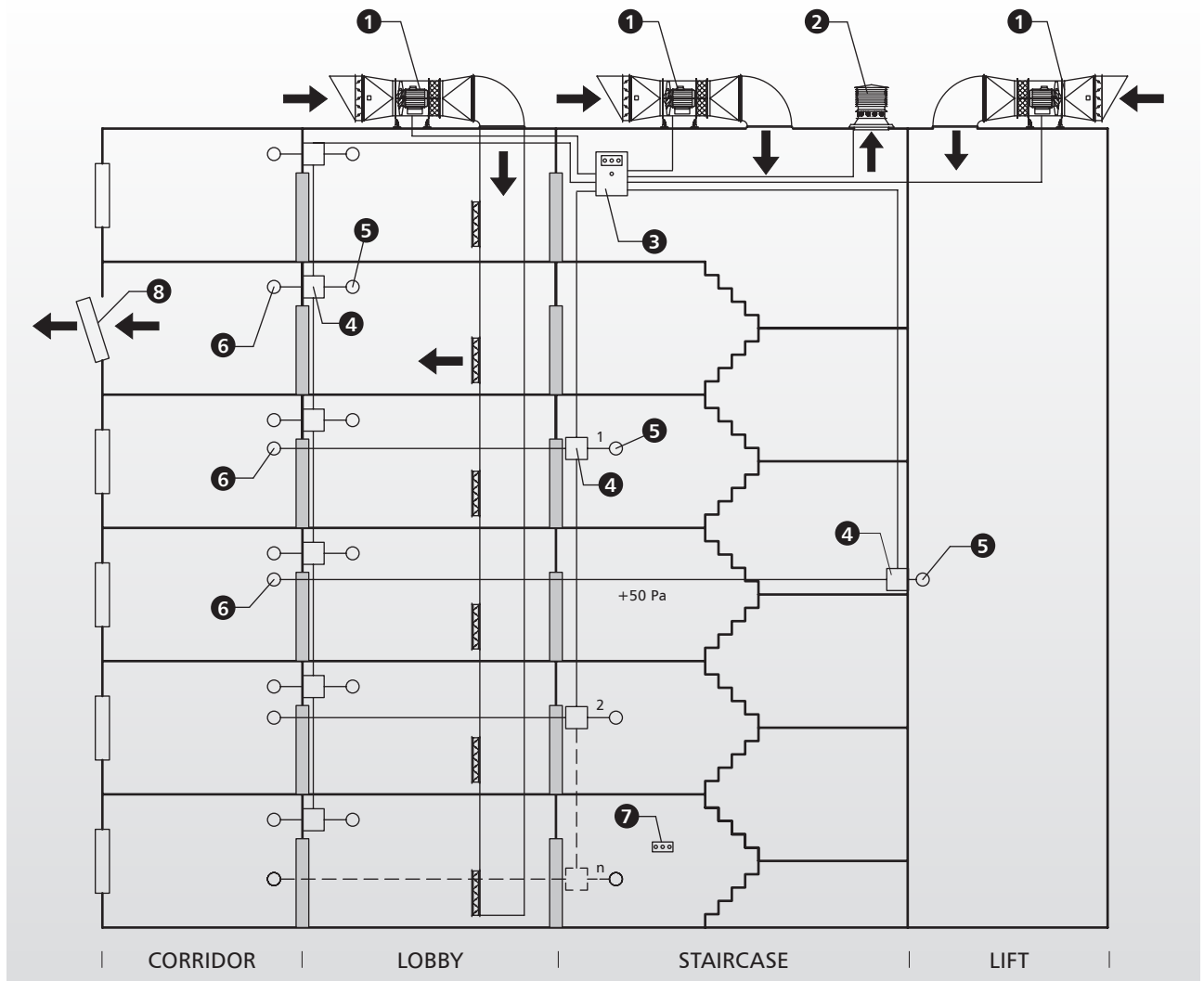

1. air supply unit with air damper and smoke detector
2. unseal of protected area mcr RPC (optional)
3. mcr Omega power and control unit(s)

4. pressure differential converter
5. pressure measurement point
6. reference point
7. PSR manual control panel
8. air release

Pressure differential converters should be mounted out of reach of unauthorised persons in the protected area (e.g. staircase):

- pressure tube [5]: protected area, away from outlet/intake grills, windows or places with intense air movement;
- pressure tube [6]: reference room (most commonly escape corridor) away from outlet/intake grills, windows or places with intense air movement.

Pressure tubes should be installed in a way that ensures free flow of air. The tubes must be connected securely and in a way that ensures airtightness. The endings of the tubes should be secured with pressure measurement points. If the tubes run outdoors, adequate protection from the weather should be provided, or use low-temperature resistant pressure tubes. Maximum length of the pressure tubes should not exceed 12 m. Minimum cross-section of the dedicated pipes is 8 mm.

Polarisation of the pressure tubes connection to the digital converter does not affect the measurements, as the controller reacts to absolute value of the measurements.

Polarisation of the pressure tubes connection to the analogue converter affects the measurements ('+': positive pressure area).

2.4.6. in-duct smoke detector

For the operation and measurements of the smoke detector to be correct, it must be properly installed in the air duct.

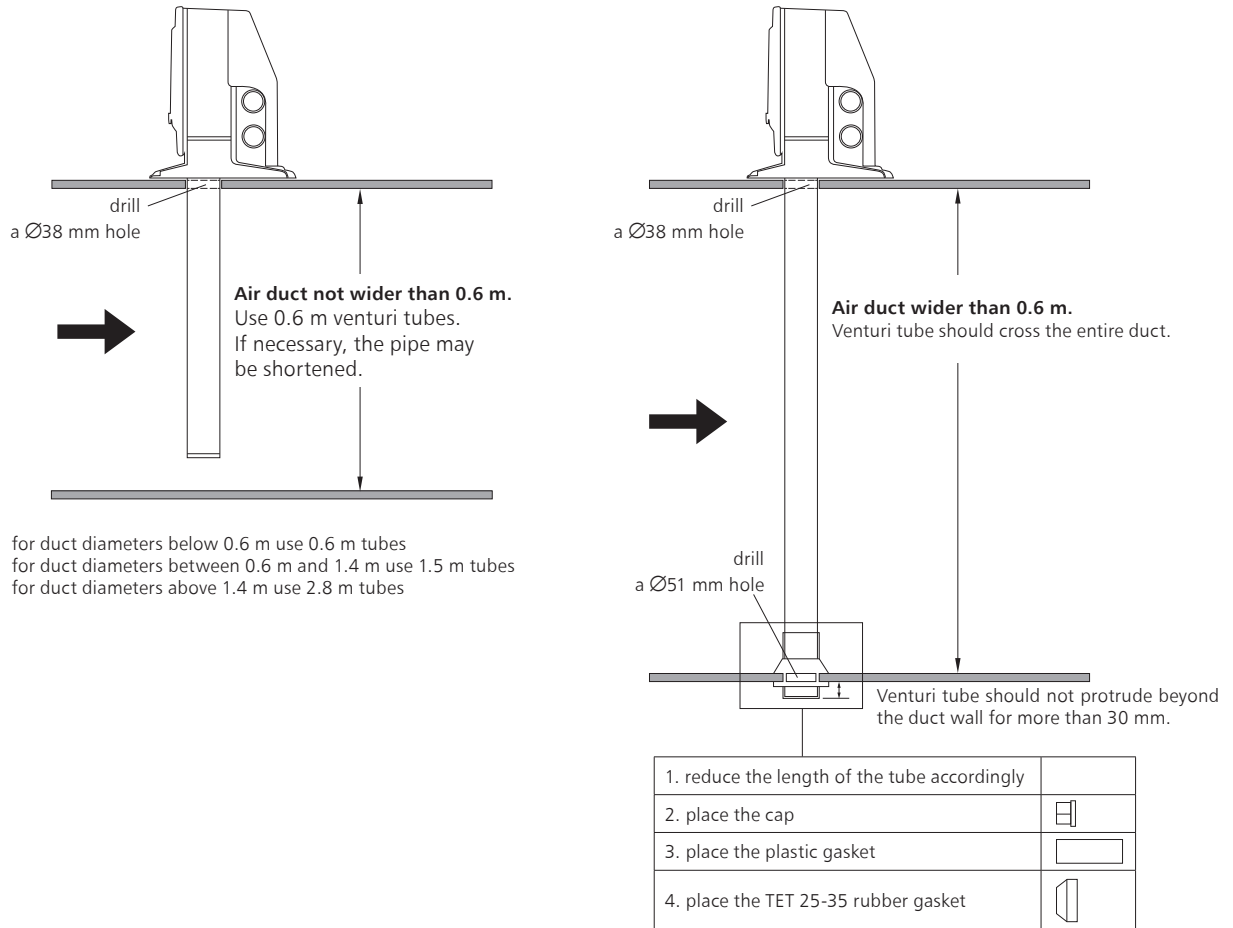

2.4.7. manual control panel

The panel should be placed near escape exits, in a location easily accessible for rescue units. The panel should be firmly fastened to the floor with min. M6 anchors.

2.4.8. duct- and wall-mounted overpressure-relief dampers

The devices are intended to be installed in walls, ducts, or outside the walls. Mounting opening dimensions: (B+90) x (H+90) mm. Dampers are available in sets with cut-off air dampers, masking grills, wind guards, and air exhausts. Before fixing into the wall, the dampers must be levelled. The dampers operate in one direction (air flow direction) - note during installation.

Example of a mcr PL wall-mounted overpressure-relief damper

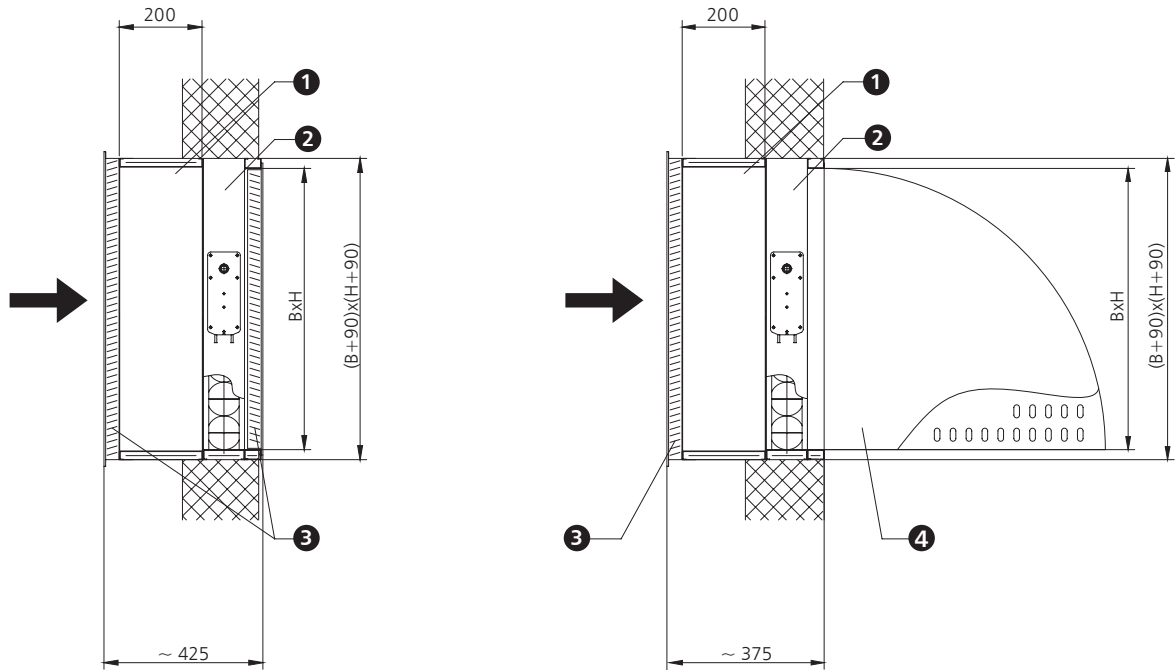

- 1. mcr PL damper
- 2. air damper
- 3. masking grill
- 4. wind guard

Example of a mcr PL duct-mounted overpressure-relief damper

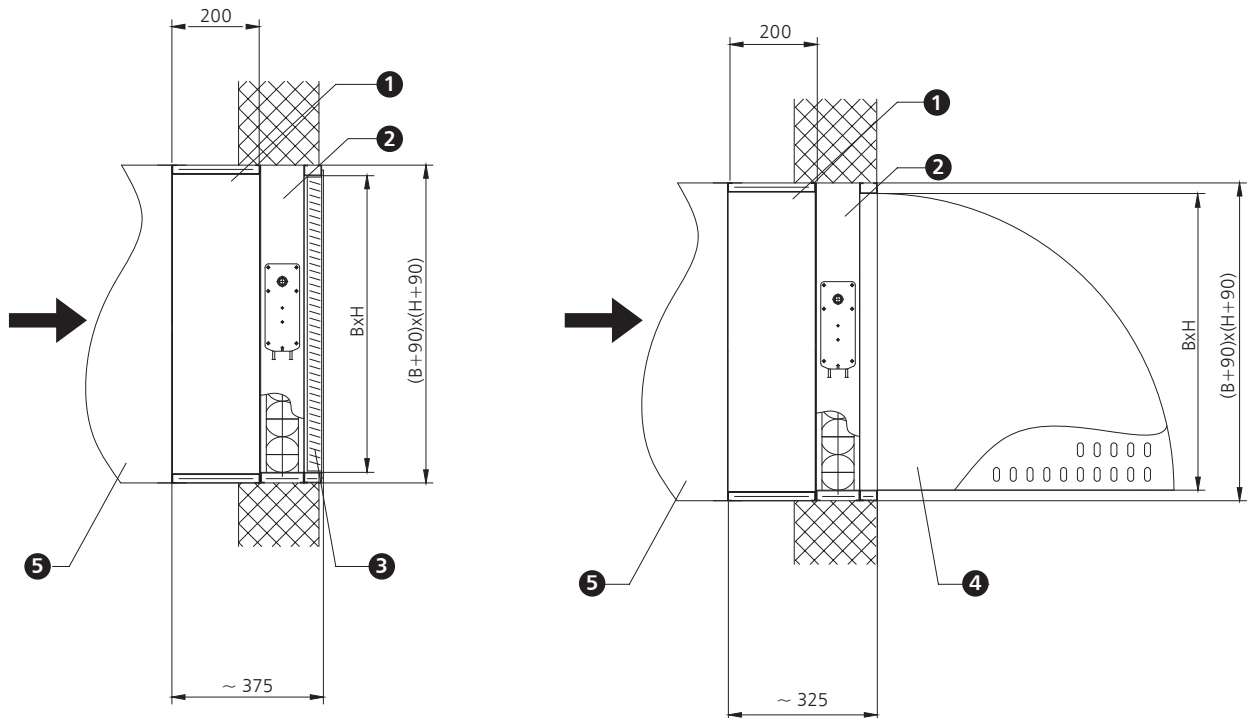

- 1. mcr PL damper
- 2. air damper
- 3. masking grill
- 4. wind guard
- 5. ventilation duct

2.4.9. overpressure-relief roof dampers

mcr PLD dampers can be mounted on dedicated roof mounting bases or on individually prepared pedestals which dimensions at the base in the clear opening corresponds to AxB mm and minimum height of 300 mm. The width of the pedestals' walls in the upper part should not be less than 55 mm. When purchasing dampers with dedicated bases, openings of AxB mm dimensions are required for installation.

Example of a mcr PLD roof-mounted overpressure-relief damper

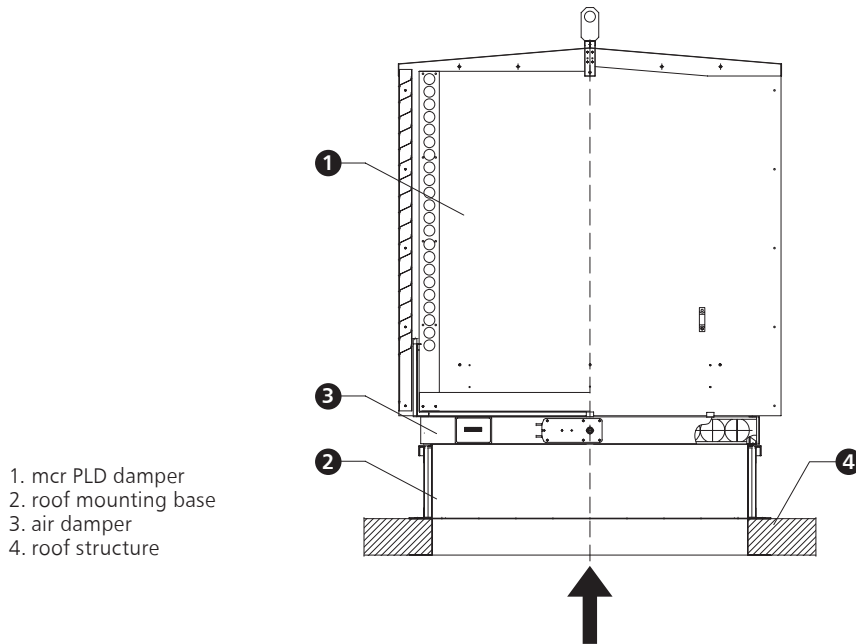

- 1. mcr PLD damper
- 2. roof mounting base
- 3. air damper
- 4. roof structure

Pedestal-mounted dampers

The structure of the pedestal may be steel, concrete, or wooden. In the sets fitted with anti-icing element, the supporting frame serves as the heating wire.

Mounting pedestal dimensions

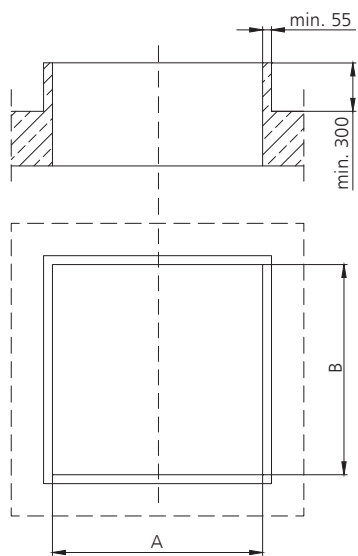

mcr PLD damper fastening to a pedestal

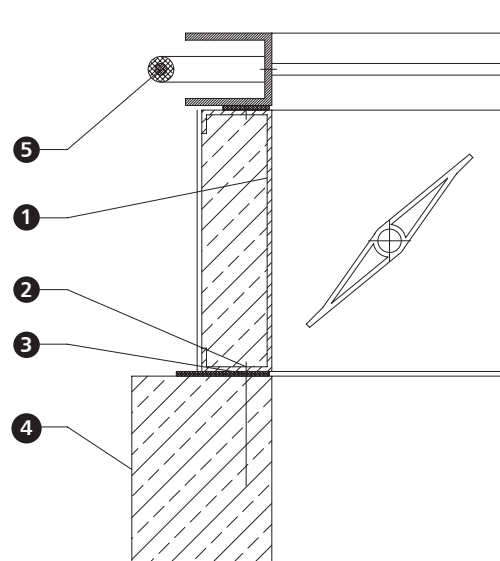

- 1. multi-blade air damper
- 2. fastener
- 3. ventilation gasket
- 4. pedestal
- 5. frame with the heating wire (optional)

Dampers mounted on dedicated bases

The base, produced by the manufacturer, is mounted onto structural elements of the roof such as purlins, trimmers, structural sheet metal, and reinforced concrete pedestals

In its lower part, the mounting base has a ledge for resting and fastening the damper to the supporting structure. Depending on the material of the supporting structure an appropriate fastener has to be selected (min. 6 mm diameter).

mcr PLD damper base installation onto dedicated mounting bases

steel structure

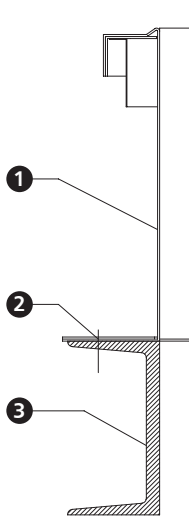

- 1. the base of the set
- 2. fixing screw
- 3. support structure
steel profile

reinforced concrete structure

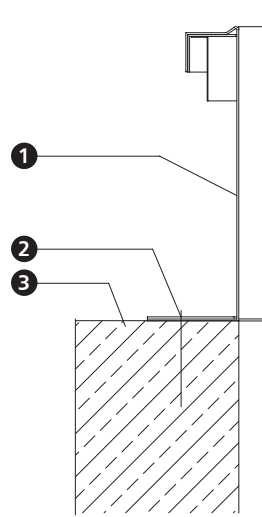

- 1. the base of the set
- 2. wall plug
- 3. support structure reinforced
concrete pedestal

wooden structure

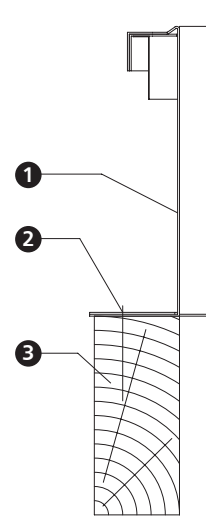

- 1. the base of the set
- 2. wood screw
- 3. wooden support
structure

The mounting base of the damper is ready for roofing works with different materials like PVC membrane or sheet metal. Its upper part has galvanised steel sheet belt along its entire perimeter for fastening roof cover with screws.

2.4.10. mcr LAM louvre dampers

The installation of the dampers (especially sheet metal flashings) should be carried out in accordance with the O&MM of the device. When installing in vertical partitions or sloped surfaces, note the orientation of the device (top and bottom), in order to ensure proper operation and functioning of drainage system.

Example of sloped roof installation

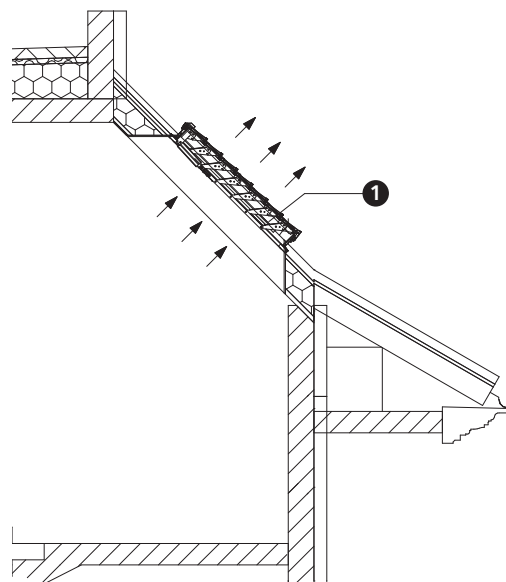

- 1. mcr LAM louvre damper

Example of wall installation

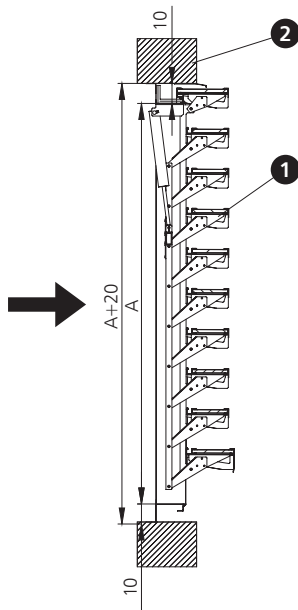

Example of ceiling installation

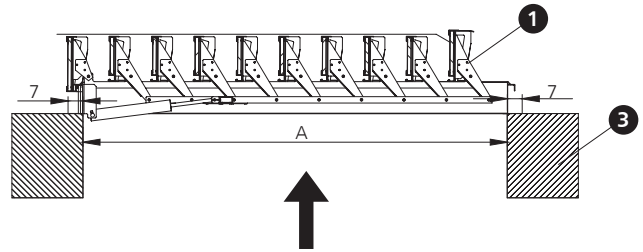

- 1. mcr LAM louvre damper
- 2. wall
- 3. ceiling

2.4.11. mcr RPC unseal of protected area

The installation of mcr RPC (especially sheet metal flashing) should be carried out in accordance with the local building rules. The bases should be fastened to the roof surface using min. M10 anchors.

- 1. roof exhaust
- 2. air damper with BFN/BF actuator
- 3. roof mounting base
- 4. roof/ceiling

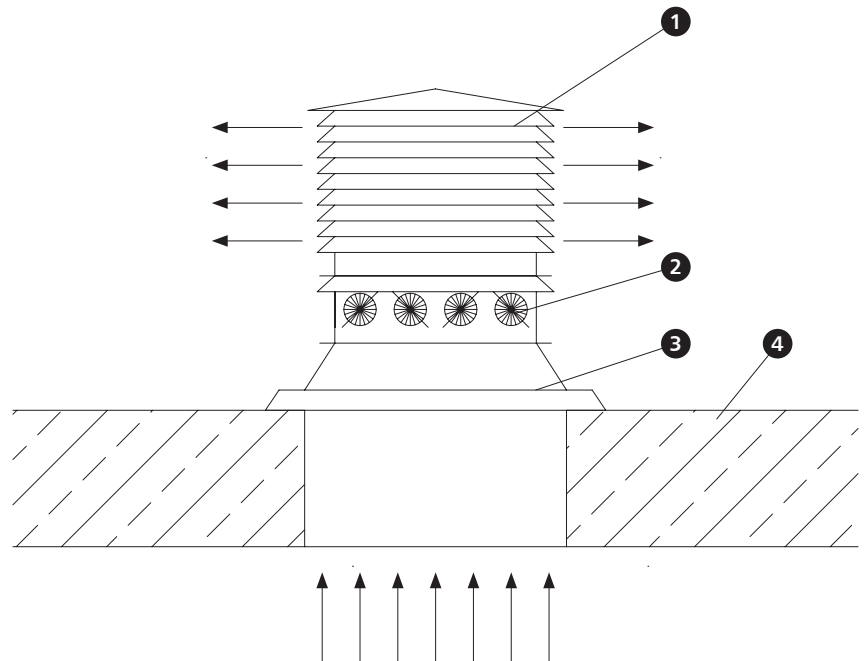

2.5. electrical connections

2.5.1. general diagram of the electrical system

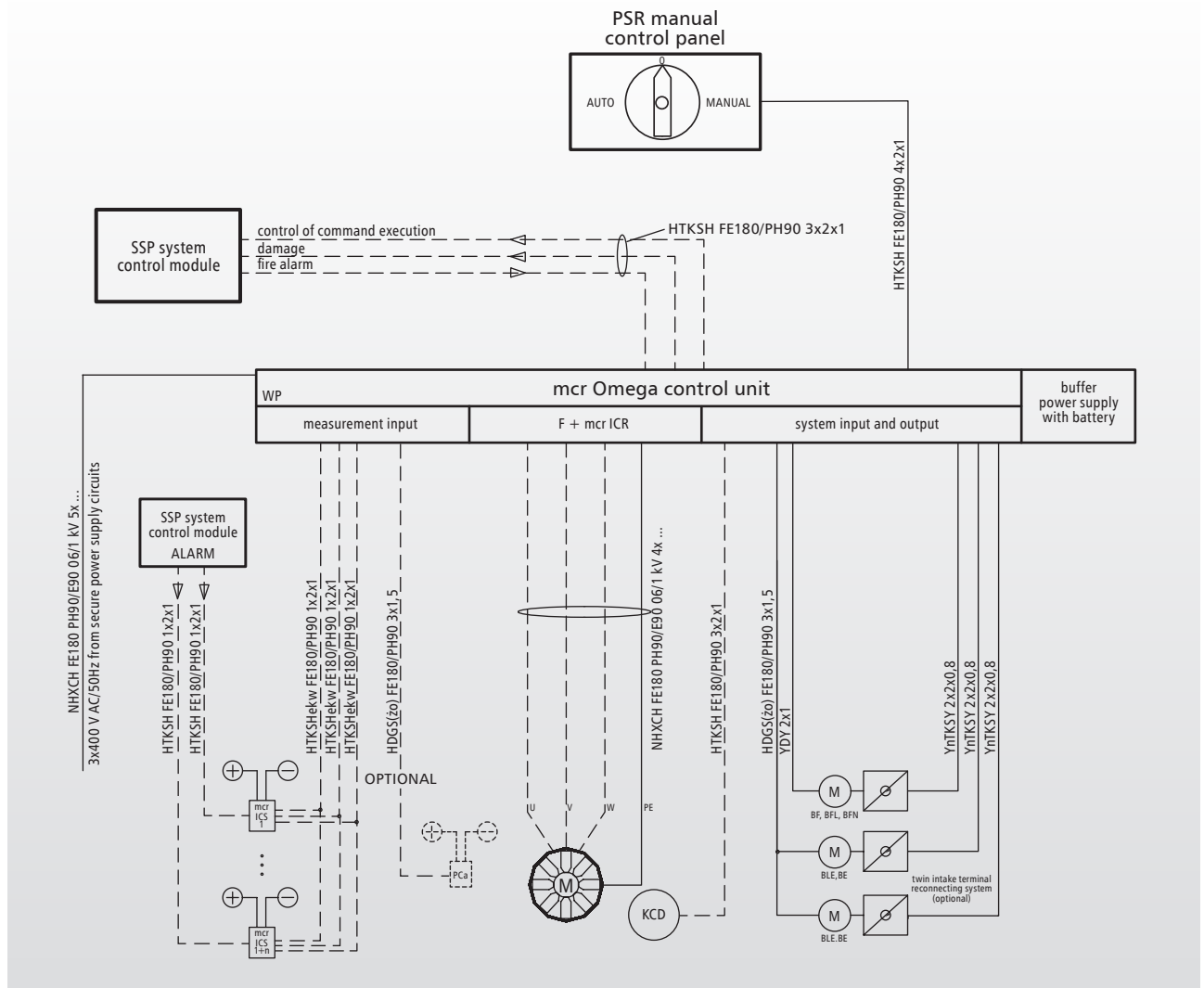

 type 984M analogue pressure converter

 mcr ICS digital pressure converter

 mcr EXi-F air supply unit

 in-duct smoke detector

 air damper

 inverter and regulation system

2.5.2. air supply units

Suggested types of power supply cables for air supply units

air supply unit	fan type	power source	type of power cables NHXCH FE 180 PH90/E90 0,6/1 kV*
mcr EXi-F 100-1M	mcr Monsun BO 100/4	mcr Omega 100M control unit	4x10
mcr EXi-F 90-1M	mcr Monsun BO 90/4	mcr Omega 100S/90M control unit	4x10
mcr EXi-F 80-1M	mcr Monsun BO 80/4	mcr Omega 80M control unit	4x6
mcr EXi-F 71-1M	mcr Monsun BO 71/4	mcr Omega 90S/71M control unit	4x4
mcr EXi-F 63-1M	mcr Monsun BO 63/4	mcr Omega 80S/63M control unit	4x2.5
mcr EXi-F 63-2M	mcr Monsun BO 63/4	mcr Omega 63M/56M control unit	4x2.5
mcr EXi-F 56-1M	mcr Monsun BO 56/4	mcr Omega 63M/56M control unit	4x2.5
mcr EXi-F 50-1M	mcr Monsun BO 50/2	mcr Omega 50M control unit	4x4
mcr EXi-F 100-1S	mcr Monsun E 100-4T-20	mcr Omega 100S/90M control unit	4x10
mcr EXi-F 90-1S	mcr Monsun E 90-4T-10	mcr Omega 90S/71M control unit	4x4
mcr EXi-F 80-1S	mcr Monsun E 80-4T-5.5	mcr Omega 80S/63M control unit	4x4
mcr EXi-F 63-1S	mcr Monsun E 63-4T-1.5	mcr Omega 63S control unit	4x1.5

*suggested cross-sections calculated for a maximum 50 m distance between the mcr Omega control unit and actuating devices

Electrical connection diagrams of air supply units' fans

air supply unit	fan type	motor connection diagram
mcr EXi-F 100-1M	mcr Monsun BO 100/4	delta
mcr EXi-F 90-1M	mcr Monsun BO 90/4	delta
mcr EXi-F 80-1M	mcr Monsun BO 80/4	delta
mcr EXi-F 71-1M	mcr Monsun BO 71/4	delta
mcr EXi-F 63-1M	mcr Monsun BO 63/4	star
mcr EXi-F 63-2M	mcr Monsun BO 63/4	star
mcr EXi-F 56-1M	mcr Monsun BO 56/4	star
mcr EXi-F 50-1M	mcr Monsun BO 50/2	star
mcr EXi-F 100-1S	mcr Monsun E 100-4T-20	delta
mcr EXi-F 90-1S	mcr Monsun E 90-4T-10	delta
mcr EXi-F 80-1S	mcr Monsun E 80-4T-5.5	star
mcr EXi-F 63-1S	mcr Monsun E 63-4T-1.5	star

Connection diagrams of air supply units' terminal boxes' windings

connection: STAR

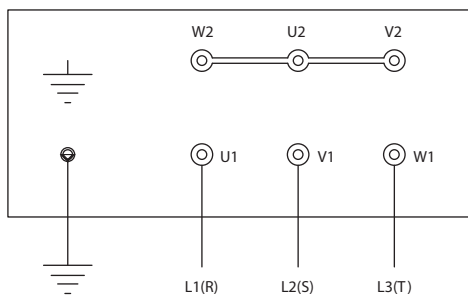

connection: DELTA

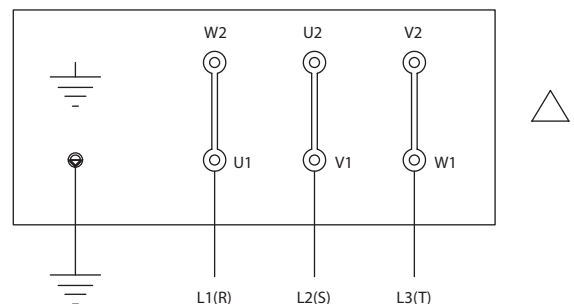

Electrical diagram of air supply unit's maintenance switch connections

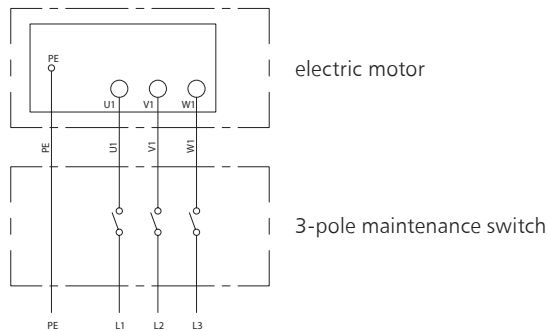

2.5.3. mcr Omega power and control unit

mcr Omega control unit	control unit's supply voltage [V]	control unit's main protection [A]	preferred protection at main switchgear [A]	min. inverter power at the control unit [kW]
mcr Omega 100M control unit	400 V AC +10%, -15%	C63	gG100	22
mcr Omega 100S/90M control unit	400 V AC +10%, -15%	C50	gG63	18.5
mcr Omega 80M control unit	400 V AC +10%, -15%	C40	gG63	15
mcr Omega 90S/71M control unit	400 V AC +10%, -15%	C32	gG50	11
mcr Omega 80S/63M control unit	400 V AC +10%, -15%	C20	gG35	5.5
mcr Omega 63M/56M control unit	400 V AC +10%, -15%	C20	gG35	4
mcr Omega 50M control unit	400 V AC +10%, -15%	C32	gG50	7.5
mcr Omega 100S/90M control unit	400 V AC +10%, -15%	C50	gG63	18.5
mcr Omega 90S/71M control unit	400 V AC +10%, -15%	C32	gG50	11
mcr Omega 80S/63M control unit	400 V AC +10%, -15%	C20	gG35	5.5
mcr Omega 63S control unit	400 V AC +10%, -15%	C10	gG20	2.2

Note:

The value of main protection of the control unit, the protection at the main switchgear, and the inverter power are true for a set-up with single Omega control unit powering a single air supply unit.

2.5.4. pressure differential converters, pressure measurements points

2.5.4.1. mcr ICS pressure differential converter

Supply voltage of the converter is 24 V AC/DC. The converter should be electrically connected with the mcr ICR controller installed in the mcr Omega control unit. The data is sent between the converter and the central unit via mcr BUS protocol. The communication runs through a separate cable. The converter has a separate alarm input (INPUT) for receiving alarm signal, e.g. for a protected lobby.

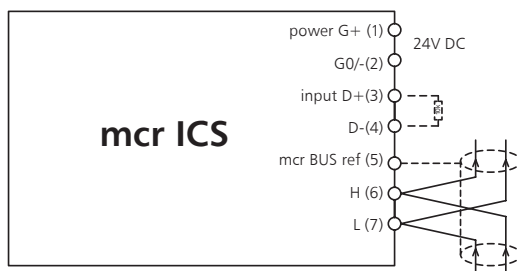

1-2: powered from mcr Omega control unit
 3-4: signal from fire control panel for the lobby from the SSP
 5-6-7 module: mcr Omega control unit communication bus

Suggested types of electrical cables for connecting the converter

component	function	power/control source	cable types*
mcr ICS digital pressure converter	power supply and signalling	mcr Omega control unit ... (mcr ICR overpressure regulator)	2xHTKSH FE180 PH90 ekw 1x2x1, HTKSH FE180 PH90 1x2x1
mcr ICS digital pressure converter (CSP: protected lobbies)	power supply and signalling	SSP system, command module	HTKSH 1x2x1

*suggested cross-sections calculated for a maximum 50 m distance between the mcr Omega control unit and actuating devices

2.5.4.2. type 984M analogue pressure converter

Supply voltage of the converter is 24 V AC/DC. Converter operates within a pressure range from 0 Pa to 100 Pa. Output signal from the converter to mcr Omega central unit is 0...10 V.

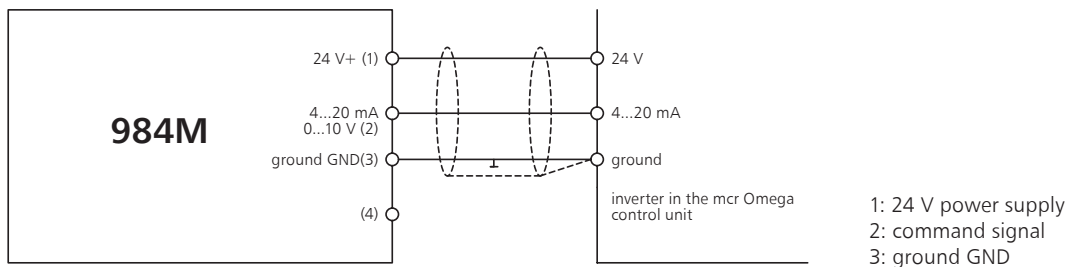

Suggested types of electrical cables for connecting the converter

component	function	power source	cable types*
analogue pressure converter	power supply and signalling	mcr Omega control unit ...	HTKSH FE180 PH90 ekw 2x2x1

*suggested cross-sections calculated for a maximum 50 m distance between the mcr Omega control unit and actuating devices

2.5.5. in-duct smoke detector

In-duct smoke detector is fitted with relay outputs for fire signalling (smoke detection) and technical alarm signalling (maintenance).

Electrical diagram of in-duct smoke detector connections

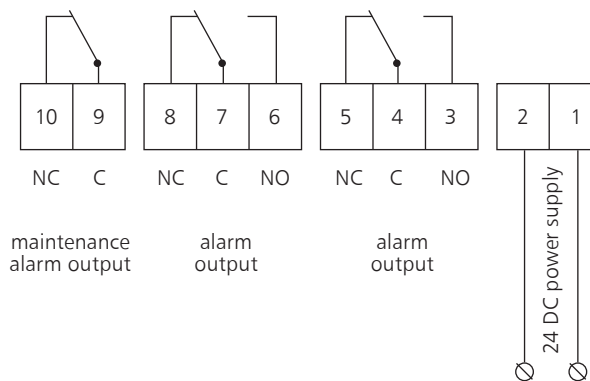

Suggested types of electrical cables for connecting the detector

component	function	power source	cable types*
in-duct smoke detector	power supply and signalling	mcr Omega control unit ...	HTKSH FE180 PH90 3x2x1

*suggested cross-sections calculated for a maximum 50 m distance between the mcr Omega control unit and actuating devices

2.5.6. manual control panel

terminal block

	1.	2.	3.	4.	5.	6.	7.	8.
X1:	power supply	damage blocking	alarm	fan operation	GND	system start	system stop	GND

Suggested types of electrical cables for connecting the panel

component	function	power source	cable types*
manual control panel	power supply and signalling	mcr Omega control unit ...	HTKSH FE180 PH90 4x2x1

*suggested cross-sections calculated for a maximum 50 m distance between the mcr Omega control unit and actuating devices

2.5.7. air dampers

The air dampers are used in such elements of the system as air supply units, U2 intake terminal reconnecting system, overpressure-relief dampers, and mcr RPC. The air dampers are fitted with Belimo axial actuators. Depending on air damper's intended use and function, it is equipped either with spring return or non-spring return actuators.

BF, NF, BFL, BFN actuators: air damper for air supply units, mcr PL and mcr PLD dampers, mcr RPC system.

BE, BLE actuators: air damper for U2 intake terminal reconnecting system.

Suggested types of electrical cables for connecting the air dampers

component	function	power source	cable types*
air damper - BE, BLE actuator	power supply	mcr Omega control unit ...	HdGs FE 180 PH90/E90 3x1,5
air damper - BE, BLE actuator	limit switches	mcr Omega control unit ...	YnTKSY 2x2x0,8
air damper - BF, NF, BFL, BFN actuator	power supply	mcr Omega control unit ...	YdY 2x1
air damper - BF, NF, BFL, BFN actuator	limit switches	mcr Omega control unit ...	YnTKSY 2x2x0,8

*suggested cross-sections calculated for a maximum 50 m distance between the mcr Omega control unit and actuating devices

Actuators' basic electrical specification

dane techniczne - silowniki	BFL24	BFL230	BFN24	BFN230	BF 24	BF230
power supply	AC 24 V 50/60 Hz DC 24 V	AC 220-240 V 50/60 Hz	AC 24 V 50/60 Hz DC 24 V	AC 220,240 50/60 Hz	AC 24 V 50/60 Hz DC 24 V	AC 220,240 50/60 Hz
power consumption - for spring loading - in rest position	2.5 W 0.7 W	3 W 0.9 W	4 W 1.4 W	4.5 W 2 W	7 W 2 W	8.5 W 3 W
wire sizing (apparent power)	4 V A	6.5 V A	6 V A	9 V A	10 V A	11 V A
protection class	III	II	III	II	III	II
degree of protection	IP 54	IP 54	IP 54	IP 54	IP 54	IP 54
auxiliary switch	2xSPDT 3(0.5) A, AC 250 V	2xSPDT 3(0.5) A, AC 250 V	2xSPDT 3(0.5) A, 250 V	2xSPDT 3(0.5) A, 250 V	2xEPU 3(0.5) A, 250 V	2xEPU 3(0.5) A, 250 V
switching points [degrees]	5°, 80°	5°, 80°	5°, 80°	5°, 80°	5°, 80°	5°, 80°
torque - motor - spring return	4 Nm 3 Nm	4 Nm 3 Nm	9 Nm 7 Nm	9 Nm 7 Nm	18 Nm 12 Nm	18 Nm 12 Nm
cable connection - motor (0.9 m length) - auxiliary switch	2x0.75 mm ² 6x0.75 mm ²	2x0.75 mm ² 6x0.75 mm ²	2x0.75 mm ² 6x0.75 mm ²	2x0.75 mm ² 6x0.75 mm ²	2x0.75 mm ² 6x0.75 mm ²	2x0.75 mm ² 6x0.75 mm ²
running time (0-90°) - motor - spring return	< 60 s ~ 20 s	< 60 s ~ 20 s	< 60 s ~ 20 s	< 60 s ~ 20 s	< 120 s ~ 16 s	< 120 s ~ 16 s
operating temperature range	-30°C...+55°C	-30°C...+55°C	-30°C...+55°C	-30°C...+55°C	-30°C...+50°C	-30°C...+50°C
sound power level - motor - spring return	max 43 dB (A) ~ 62 dB (A)	max 43 dB (A) ~ 62 dB (A)	max 55 dB (A) ~ 67 dB (A)	max 55 dB (A) ~ 67 dB (A)	max 45 dB (A) ~ 63 dB (A)	max 45 dB (A) ~ 63 dB (A)

technical specifications - actuators	BE24	BE230	BLE24	BLE230
power supply	AC 24 V 50/60 Hz DC 24 V	AC 220-240 V 50/60 Hz	AC 24 V 50/60 Hz DC 24 V	AC 230 50/60 Hz
power consumption:				
- in operation	12 W	8 W	7.5 W	5 W
- in rest position	0.5 W	0.5 W	0.5 W	< 1 W
wire sizing (apparent power)	18 V A	15 V A	9 V A	12 V A
protection class	III	II	III	II
degree of protection	IP 54	IP 54	IP 54	IP 54
auxiliary switch	2xSPDT	2xSPDT	2 x EPU	2 x EPU
	6 (3) A, AC 250 V	6 (3) A, AC 250 V	3 (0.5) A, 250 V	3 (0.5) A, 250 V
switching points [degrees]	5°, 80°	5°, 80°	5°, 80°	5°, 80°
torque: motor	40 Nm	40 Nm	15 Nm	15 Nm
running time (0-90°): motor	< 60 s	< 60 s	< 30 s	< 30 s
operating temperature range	-30°C...+50°C	-30°C...+50°C	-30°C...+50°C	-30°C...+50°C
sound power level	~ 62 dB (A)	~ 62 dB (A)	~ 62 dB (A)	~ 62 dB (A)

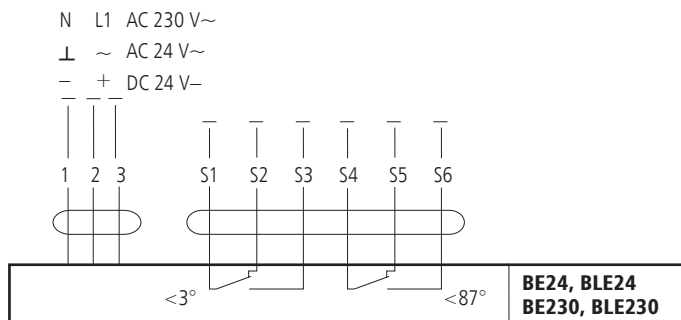
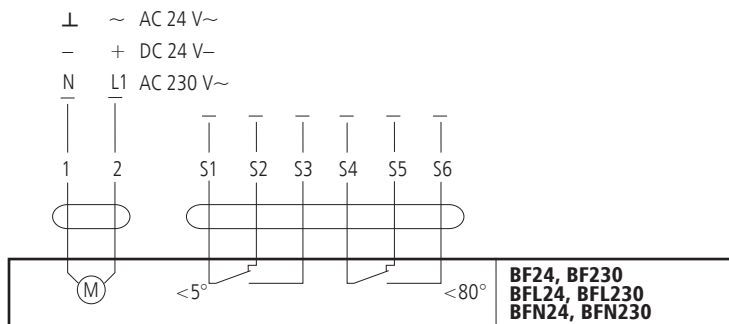

Note:

For BE and BLE actuators control three-core cables are necessary. The direction of actuators' rotation can be controlled by adequately connecting supply voltage to the terminals 2 or 3.

Limit switches' position of for all types of actuators is presented in a volt free position.

For proper functioning of devices fitted with electric actuators it is advisable that the nominal rated supply voltage fell within $24 V \pm 10\%$ or $230 V \pm 10\%$ tolerance bands. Powering devices with a different voltage than those presented above may cause malfunctioning of the device.

2.5.8. anti-icing system for type SP air dampers

The air dampers may be fitted with an anti-icing system. It consists of a special steel frame with flanges, thermally insulated on one side, with a heating wire installed along its perimeter. The device uses for connection a terminal box mounted on its frame, fitted with a controller.

The frame is adapted for direct installation onto the air damper. Its dimensions are strictly adjusted to the size of air supply units. Should it be necessary, two heating frames may be mounted, one on each side of the air damper.

Controller's power supply is signalled with a green LED light. Controller's operation (heating) is signalled with a red LED light.

For proper functioning of the device, voltage must be supplied to terminals 3 and 4 of the controller. The values of temperature and 'hysteresis' are set using the controller's potentiometers.

Temperature controller technical specifications	
power supply	230 V AC
load current	< 16 A
temperature adjustment range	-4 ÷ 5°C
controlled hysteresis	0.5 ÷ 3°C
temperature sensor	KTY 10-6
sensor probe length	cable 2,5 m
power supply signalling	green LED
operation signalling	red LED
power consumption	1.1 W
connection	2 modules (35 mm)
installation	TH35 rail

Temperature controller connection diagram

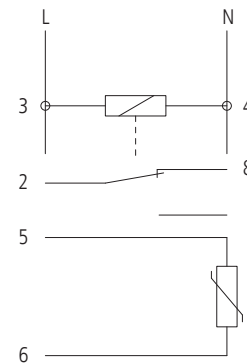

2.5.9. mcr LAM louvre damper

Device's electrical connections diagram

Damper opens:
 "+" - brown cable
 "-" - blue cable
 Damper shuts:
 "+" - blue cable
 "-" - brown cable

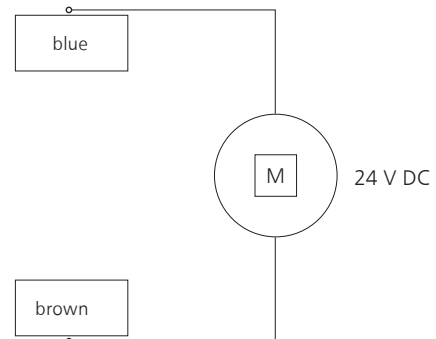

Technical specifications			
damper sealing variant	standard	option D05/D07	option IP42
damper's actuator supply voltage	24 V DC		
actuator's current draw	0.8 A for SL0 0.8 A...3 A for SL250...SL950		
dependability in low temperatures	down to -25°C		
heat resistance	up to 300°C		
DIN EN 60 529 protection degree	IP40	IP54	IP42

Suggested types of electrical cables for connecting the damper

component	function	power source	cable types*
mcr LAM	power	mcr Omega control unit ...	HDGs 2x2,5

* suggested cross-sections calculated for 1 A current draw, a maximum 50 m distance between the mcr Omega control unit and actuating devices

Detailed information on mcr LAM louvre dampers is available in the "MERCOR" S.A. Technical Catalogue for smoke and heat exhaust, and roof-light systems.

2.6. system's components designation

mcr EXi-F 1_2_3_4_5_6_7_8_9_10_11_12_13_14_15_16_17_18_19_20_21_22_23_24_25

	no	position	symbol	notes
air supply units + automatic systems	1	air supply unit type	100-1M	mcr Monsun BO fan in cylindrical housing
			90-1M	mcr Monsun BO fan in cylindrical housing
			80-1M	mcr Monsun BO fan in cylindrical housing
			71-1M	mcr Monsun BO fan in cylindrical housing
			63-1M	mcr Monsun BO fan in cylindrical housing
			63-2M	mcr Monsun BO fan in cylindrical housing
			56-1M	mcr Monsun BO fan in cylindrical housing
			50-1M	mcr Monsun BO fan in cylindrical housing
			100-1S	mcr Monsun BO fan in box housing
			90-1S	mcr Monsun E fan in box housing
			80-1S	mcr Monsun E fan in box housing
	2	vertically oriented fan	UP	mcr Monsun E fan in box housing
	3	system equipped with a back-up fan	UR	second unit, same parameters as the primary one
	4	power supply and control automatic systems	S	standard version - basic unit
			R	system with a primary and a back-up unit
			P	system with vertically orientated air supply unit - UP
			PR	system with vertically orientated air supply and back-up units
	5	version	STD	standard (painted fan, galvanised steel equipment)
			ML	painted components (fan and painted equipment)
			SN	stainless steel equipment and fan housing elements
	6	mounting feet for air supply unit fan	SW + pcs	mounting feet for mcr Monsun BO fan, ... pcs
	7	shock absorbers for air supply unit fan	AM + pcs	shock absorbers for mcr Monsun BO fan, ... pcs
	8	mounting feet for air supply unit fan	Bfoot + pcs	Big Foot mounting feet, ... pcs
	9	pressure converter pressure tube	E + set	5 m set of pressure tube with connections
	10	mechanical differential pressure switch	PRE	pressure switch for back-up unit installation
	11	maintenance switch for air supply unit fan	WS	maintenance switch for installation on the air supply unit
discharge side of the system	12	system's noise suppressor	To + pcs	round noise suppressor for mcr Monsun BO fan, ... pcs
			Tp + pcs	rectangular noise suppressor for mcr Monsun E or mcr Monsun BO fans, ... pcs
	13	cut-off air damper with actuator	P	fitted with Belimo actuator as a standard
	14	system's flexible connection	KO	flexible round connection
KP			flexible rectangular connection	
15	system's symmetrical diffuser	D	mcr Monsun BO fan diffuser	
suction side of the system	16	system's symmetrical diffuser	D	mcr Monsun BO fan diffuser
			KO	flexible round connection
	17	system's flexible connection	KP	flexible rectangular connection
18	cut-off air damper with actuator	P		
19	intake nozzle	DWO + pcs	exhaust nozzle for mcr Monsun BO fan, ... pcs	
		DWP + pcs	60° angled rectangular duct for mcr Monsun BO fan, ... pcs	
other	20	pressure converters	PC + pcs	digital pressure converter + 2m tubes set with connections and two pressure measurement points, ... pcs
			PA + pcs	analogue pressure converter, 2 m tubes set, ... pcs
	21	intake terminal reconnecting system	U2	set includes two inlets fitted with actuators
	22	indoor variant of in-duct smoke detector	C + pcs	in-duct smoke detector, . pcs
	23	system's manual control panel	PSR	
	24	outdoor variant of in-duct smoke detector	CW + pcs	in-duct smoke detector, ... pcs
25	anti-icing system	SP + A	anti-icing system for air damper system: SP + U2: for U2 air damper system SP + P: for P type air dampers	

If a given piece of equipment is absent, the number in the code of the system is substituted with an 'X'.

If a given piece of equipment is present, the number in the code of the system is substituted with its designation.

Designation of a piece of equipment is followed by a number defining the quantity of pieces or sets.

If the system has additional mcr PL or mcr PLD dampers or a mcr RPC permanent unsealing, they should be specified separately.

Example**F 100 -1M _X_X_S_STD_SW2_AM4_X_E2_X_WS_X_P_KO_D_X_KO_X_DWO_PC4_X_X_PSR_X**

mcr EXi-F pressurisation system with a 100-1M air supply unit for horizontal operations, without back-up unit, with mcr Omega power and control unit in standard version, standard painting (unit: painted, remaining equipment: galvanised steel), with two mounting feet with four shock absorbers for air supply unit installation, with two sets of pressure tubes for pressure converter (10 m), with air supply unit maintenance switch, with regulating/cut-off air damper on the discharge side of the unit, with flexible connection and diffuser on the discharge side, with flexible connection and inlet nozzle on the suction side, four digital pressure converters and a manual system control panel.

mcr PLD/800x800/P230/PD

800x800 roof damper for mcr EXi-F with a 230 V AC powered air damper, with a PD roof mounting base.

mcr RPC/600x600/P230

600x600 permanent system unseal with a 230 V AC powered air damper.