



ul. Grzegorza z Sanoka 2  
80-408 Gdańsk  
Phone: (0-58) 341 42 45  
tel./fax (0-58) 341 39 85

---

## **OPERATION AND MAINTENANCE MANUAL (OMM)**

### **mcr FID PRO type fire damper**



Rev. FID PRO 18.11.14.8

## CONTENTS:

1. INTRODUCTION .....	3
2. SUBJECT OF THE MANUAL .....	3
3. INTENDED USE OF THE FIRE DAMPER .....	3
4. DESIGN AND OPERATING PRINCIPLE OF THE FIRE DAMPER.....	4
5. MANUFACTURER'S DESIGNATION OF THE FIRE DAMPER.....	6
6. INSTALLATION OF THE FIRE DAMPER.....	6
6.1. PRE-INSTALLATION INSPECTION .....	6
6.2. INSTALLATION OPENING.....	7
6.3. BUILDING IN THE FIRE DAMPER.....	7
6.4. ELECTRICAL CONNECTIONS.....	12
7. TRANSPORT AND STORAGE CONDITIONS .....	16
8. MAINTENANCE AND SERVICE (REPAIRS) .....	17
9. WARRANTY TERMS AND CONDITIONS .....	17

## Markings used in the OMM

- Option available
- Option unavailable

# mcr FID PRO single-plane fire dampers

## NOTE

As at the date of issue of this Operation and Maintenance Manual, previous revisions become invalid. The Operation and Maintenance Manual does not apply to fire dampers manufactured before the date of its issue.

### 1. INTRODUCTION

The aim of this Operation and Maintenance Manual is to make the user familiar with the intended use, design, operating principle, correct installation and operation of the product. The OMM also contains additional information on the conditions of use, maintenance and warranty of the product.

### 2. SUBJECT OF THE MANUAL

This OMM applies to a whole group of mcr FID PRO type single-plane fire dampers. Complying with the recommendations included in the OMM will ensure proper functioning of the fire damper in its purpose of being a fire protection system used in interior spaces as well as the safety of its users.

### 3. INTENDED USE OF THE FIRE DAMPER

#### Use

The mcr FID PRO type single-plane fire dampers may be used as:

- mcr FID PRO/S fire dampers
- mcr FID PRO/V fire dampers for fire ventilation systems
- mcr FID PRO/M fire dampers for mixed-mode fire ventilation systems
- mcr FID PRO/T transfer dampers
- mcr FID PRO/G pressure relief dampers

Fire dampers are not designed to work in ventilation systems where there is a risk of them coming into contact with dust-laden air unless they have been covered by a special, tailor-made service and technical inspections programme.

#### Fire resistance

The fire resistance ratings of the mcr FID PRO type fire dampers are as follows:

<input checked="" type="checkbox"/> EI60S	<input type="checkbox"/> /S	<input type="checkbox"/> /V	<input type="checkbox"/> /M	<input type="checkbox"/> /T	<input type="checkbox"/> /G	<input checked="" type="checkbox"/> EI120S	<input type="checkbox"/> /S	<input type="checkbox"/> /V	<input type="checkbox"/> /M	<input type="checkbox"/> /T	<input type="checkbox"/> /G
<input type="checkbox"/> EI60	<input type="checkbox"/> /S	<input type="checkbox"/> /V	<input type="checkbox"/> /M	<input type="checkbox"/> /T	<input type="checkbox"/> /G	<input type="checkbox"/> EI120	<input type="checkbox"/> /S	<input type="checkbox"/> /V	<input type="checkbox"/> /M	<input type="checkbox"/> /T	<input type="checkbox"/> /G
<input type="checkbox"/> E60S	<input type="checkbox"/> /S	<input type="checkbox"/> /V	<input type="checkbox"/> /M	<input type="checkbox"/> /T	<input type="checkbox"/> /G	<input type="checkbox"/> E120S	<input type="checkbox"/> /S	<input type="checkbox"/> /V	<input type="checkbox"/> /M	<input type="checkbox"/> /T	<input type="checkbox"/> /G
<input type="checkbox"/> E60	<input type="checkbox"/> /S	<input type="checkbox"/> /V	<input type="checkbox"/> /M	<input type="checkbox"/> /T	<input type="checkbox"/> /G	<input type="checkbox"/> E120	<input type="checkbox"/> /S	<input type="checkbox"/> /V	<input type="checkbox"/> /M	<input type="checkbox"/> /T	<input type="checkbox"/> /G
						<input checked="" type="checkbox"/> EI180S	<input type="checkbox"/> /S	<input type="checkbox"/> /V	<input type="checkbox"/> /M	<input type="checkbox"/> /T	<input type="checkbox"/> /G

The fire ratings depend on the use as well as the manner and place of fire damper installation.

#### Manufacturing versions

The mcr FID PRO type fire dampers may be manufactured as:

- rectangular fire dampers
- rectangular fire dampers with circular connections
- round fire dampers

#### Size range

The mcr FID PRO type fire dampers are manufactured in the following dimensions:

width: from 100 to 315 mm

width for nipple fire dampers: 170 mm (with an option to be extended to 310 mm)

width for coupling fire dampers: 140 mm (with an option to be extended to 280 mm)

The fire dampers may be additionally fitted with connection flanges.

Apart from the standard dimensions, there is a possibility to manufacture fire dampers with any dimensions within the above ranges. The maximum surface area of the mcr FID PRO type fire damper is 0.078 m<sup>2</sup>. The minimum surface area of these fire dampers is 0.008 m<sup>2</sup>.

### 4. DESIGN AND OPERATING PRINCIPLE OF THE FIRE DAMPER

#### Design

The mcr FID PRO single-plane fire dampers consist of a housing with a round cross section, movable cut-off partition as well as a release and control mechanism which is started remotely or automatically (after a thermal release has been actuated). Fire dampers' housings are made of galvanised steel sheet or stainless steel sheet. In the fire damper' housing, along its perimeter, there is an insulation perforation of suitable width. The fire damper's cut-off

## mcr FID PRO single-plane fire dampers

partition is made of non-flammable board. The partition is lined on both sides with sheet metal reinforcement. On the housing, in the area of insulation perforation, an intumescent seal is installed. Along its perimeter, the partition is sealed by means of a rubber seal installed on the partition.

Normally, the fire dampers have a spigot (nipple or coupling) connection. Connection flanges are available on request.

### Operation

The operating principle and behaviour of the mcr FID PRO single-plane fire dampers depends on the version and use:

#### mcr FID PRO/S fire dampers

These dampers remain open during normal operation. They are closed (safety position) in the following ways:

- automatically – by actuation of the thermoelectric release
- manually – by pressing the control button on the thermoelectric release
- remotely – by actuation of the axial electric actuator with a return spring as the supply voltage disappears
- automatically – by actuation of the thermal release and the power spring

#### mcr FID PRO/V fire dampers for fire ventilation systems

These fire dampers remain closed during normal operation. They are opened (safety position) in the following ways:

- remotely – by actuation of the axial electric actuator without a return spring as the supply voltage is appropriately applied to the actuator
- remotely – by actuation of the electromagnetic release and spring as the voltage is supplied

#### mcr FID PRO/M fire dampers for mixed-mode fire ventilation systems

Depending on the function they serve, these fire dampers remain either closed or open during normal operation. They are opened/closed (safety position) in the following ways:

- remotely – by actuation of the axial electric actuator without a return spring as the supply voltage is appropriately applied to the actuator

#### mcr FID PRO/T transfer dampers

These dampers remain open during normal operation. They are closed (safety position) in the following ways:

- automatically – by actuation of the thermoelectric release
- manually – by pressing the control button on the thermoelectric release
- remotely – by actuation of the axial electric actuator with a return spring as the supply voltage disappears
- automatically – by actuation of the thermal release and the power spring

#### mcr FID PRO/G pressure relief fire dampers

These dampers remain open during normal operation. They are closed (safety position) in the following ways:

- remotely – by actuation of the axial electric actuator with a return spring as the supply voltage disappears. The actuator does not have a thermoelectric release.

It is possible to check manually the correct functioning of a fire damper with electric actuator for maintenance purposes. To do this, use a special hex key which should be placed in the socket marked on the actuator. Then, by rotating the hex key, the fire damper's partition may be set in the desired position. Bearing in mind to take enough care, rotate the hex key uniformly and slowly. Too fast and violent rotation may cause damage to the internal mechanism of the actuator or the power transmission system.

To manually check correct operation of fire dampers with a manual release and control mechanism in the integrated version for maintenance purposes, press the lever on the mechanism.

### NOTE

**Never try to open or close a fire damper's partition by pulling it directly. Such attempts may cause damage to the self-locking powertrain of a fire damper and this is not covered by warranty.**

**It is recommended that the fire damper were opened and closed when the ventilation system is turned off.**

# mcr FID PRO single-plane fire dampers

## Release and control mechanisms

The release and control mechanism of mcr FID PRO fire dampers may be one of the following:

### Electric actuator:

<input type="checkbox"/>	BF 230-T	<input type="checkbox"/>	/S	<input type="checkbox"/>	/V	<input type="checkbox"/>	/M	<input type="checkbox"/>	/T	<input type="checkbox"/>	/G	<input type="checkbox"/>	BE 230	<input type="checkbox"/>	/S	<input type="checkbox"/>	/V	<input type="checkbox"/>	/M	<input type="checkbox"/>	/T	<input type="checkbox"/>	/G
<input type="checkbox"/>	BF 24-T (-ST)	<input type="checkbox"/>	/S	<input type="checkbox"/>	/V	<input type="checkbox"/>	/M	<input type="checkbox"/>	/T	<input type="checkbox"/>	/G	<input type="checkbox"/>	BE 24	<input type="checkbox"/>	/S	<input type="checkbox"/>	/V	<input type="checkbox"/>	/M	<input type="checkbox"/>	/T	<input type="checkbox"/>	/G
<input type="checkbox"/>	BF 24-T-TL	<input type="checkbox"/>	/S	<input type="checkbox"/>	/V	<input type="checkbox"/>	/M	<input type="checkbox"/>	/T	<input type="checkbox"/>	/G	<input type="checkbox"/>	BLE 230	<input type="checkbox"/>	/S	<input type="checkbox"/>	/V	<input type="checkbox"/>	/M	<input type="checkbox"/>	/T	<input type="checkbox"/>	/G
<input type="checkbox"/>	BFL 230-T	<input type="checkbox"/>	/S	<input type="checkbox"/>	/V	<input type="checkbox"/>	/M	<input type="checkbox"/>	/T	<input type="checkbox"/>	/G	<input type="checkbox"/>	BLE 24	<input type="checkbox"/>	/S	<input type="checkbox"/>	/V	<input type="checkbox"/>	/M	<input type="checkbox"/>	/T	<input type="checkbox"/>	/G
<input type="checkbox"/>	BFL 24-T (-ST)	<input type="checkbox"/>	/S	<input type="checkbox"/>	/V	<input type="checkbox"/>	/M	<input type="checkbox"/>	/T	<input type="checkbox"/>	/G	<input checked="" type="checkbox"/>	EXBF 230	<input checked="" type="checkbox"/>	/S	<input type="checkbox"/>	/V	<input type="checkbox"/>	/M	<input type="checkbox"/>	/T	<input type="checkbox"/>	/G
<input type="checkbox"/>	MLF 230-T1	<input type="checkbox"/>	/S	<input type="checkbox"/>	/V	<input type="checkbox"/>	/M	<input type="checkbox"/>	/T	<input type="checkbox"/>	/G	<input type="checkbox"/>	EXBF 24	<input type="checkbox"/>	/S	<input type="checkbox"/>	/V	<input type="checkbox"/>	/M	<input type="checkbox"/>	/T	<input type="checkbox"/>	/G
<input checked="" type="checkbox"/>	MLF 24-T1	<input checked="" type="checkbox"/>	/S	<input type="checkbox"/>	/V	<input type="checkbox"/>	/M	<input type="checkbox"/>	/T	<input type="checkbox"/>	/G												

### Spring mechanism:

<input checked="" type="checkbox"/>	RST	<input checked="" type="checkbox"/>	/S	<input type="checkbox"/>	/V	<input type="checkbox"/>	/M	<input type="checkbox"/>	/T	<input type="checkbox"/>	/G	<input checked="" type="checkbox"/>	RST/KW1/S	<input checked="" type="checkbox"/>	/S	<input type="checkbox"/>	/V	<input type="checkbox"/>	/M	<input type="checkbox"/>	/T	<input type="checkbox"/>	/G
<input checked="" type="checkbox"/>	RST/KW1/24P	<input checked="" type="checkbox"/>	/S	<input type="checkbox"/>	/V	<input type="checkbox"/>	/M	<input type="checkbox"/>	/T	<input type="checkbox"/>	/G	<input type="checkbox"/>	RST/KW1/24I	<input type="checkbox"/>	/S	<input type="checkbox"/>	/V	<input type="checkbox"/>	/M	<input type="checkbox"/>	/T	<input type="checkbox"/>	/G
<input checked="" type="checkbox"/>	RST/KW1/230P	<input checked="" type="checkbox"/>	/S	<input type="checkbox"/>	/V	<input type="checkbox"/>	/M	<input type="checkbox"/>	/T	<input type="checkbox"/>	/G	<input type="checkbox"/>	RST/KW1/230I	<input type="checkbox"/>	/S	<input type="checkbox"/>	/V	<input type="checkbox"/>	/M	<input type="checkbox"/>	/T	<input type="checkbox"/>	/G

## Main dimensions

female connection type (muff)

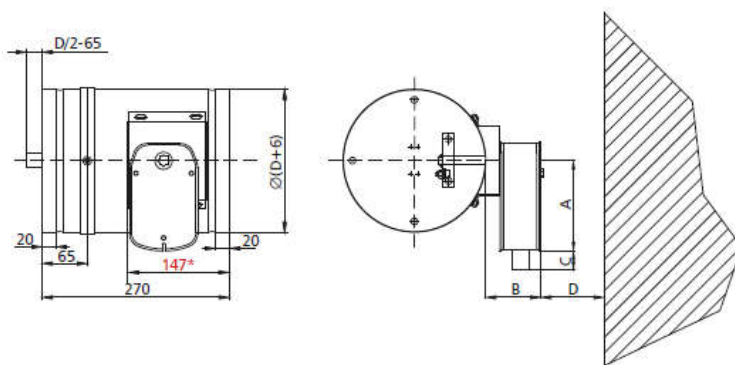

male connection type (nipple)

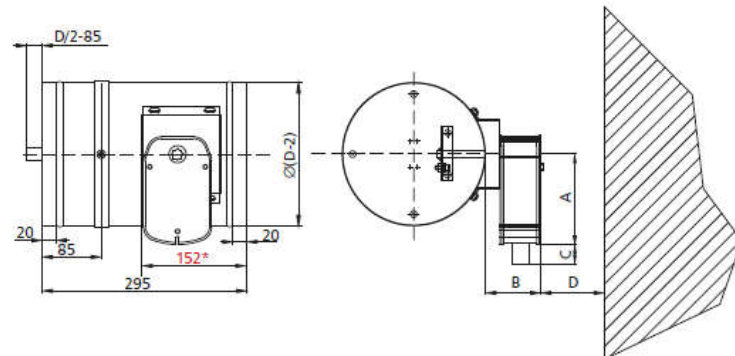

Gear	A	B	C	D
BFL	138	74	30	75
BF 24TL-ST	198	85	10	75
EXBF	225	190	55	100

\* embedding border

version with circumferential seal type F

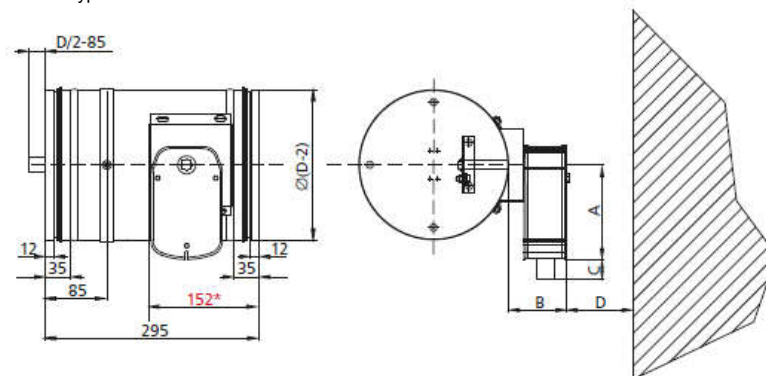

mcr FID PRO fire damper with actuator

# mcr FID PRO single-plane fire dampers

female connection type (muff)

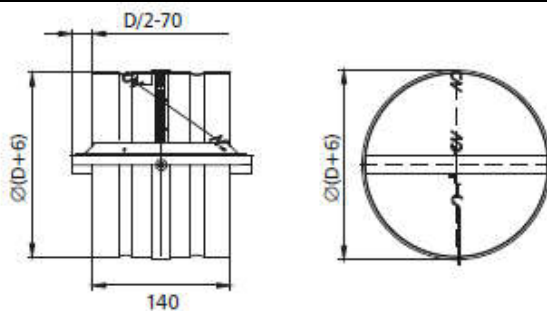

male connection type (nipple)

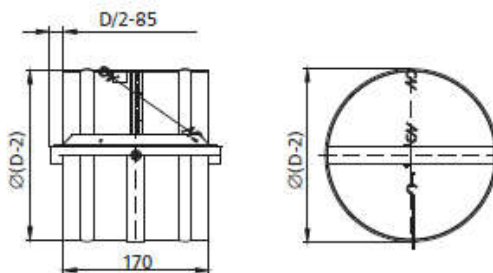

embed symmetrically with respect to axis

## mcr FID PRO fire damper with RST

female connection type (muff)

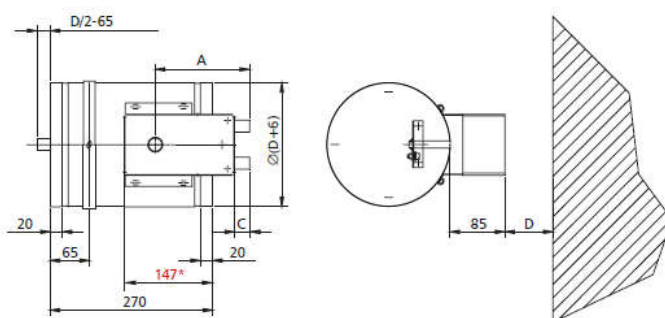

male connection type (nipple)

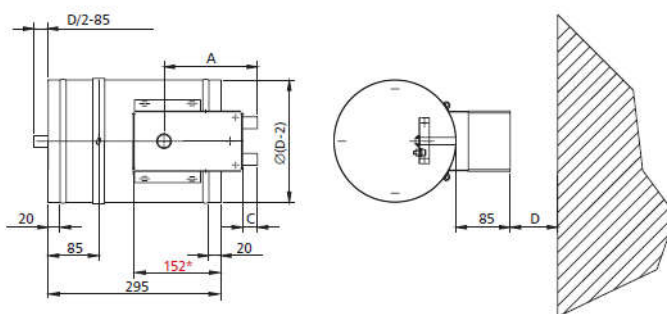

Gear	A	B	D
RST	130	30	75

\* embedding border

version with circumferential seal type F

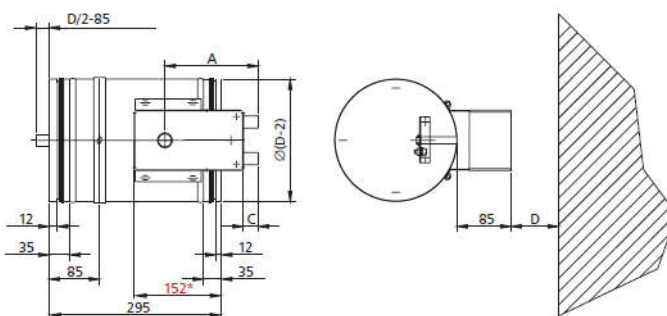

## mcr FID PRO fire damper with RST/KW1

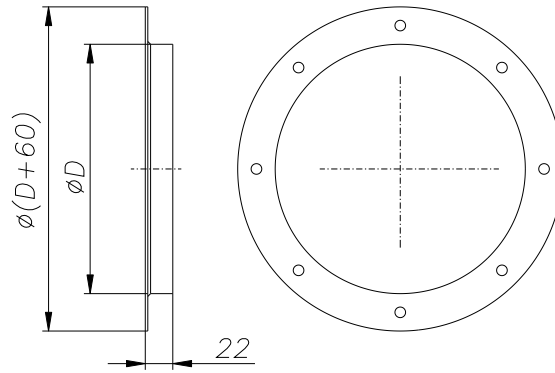

Flange dimensions in the case of the flange version of the fire damper. Spacing and quantities of openings according to EN 12220 (dimensions of flanges with circular intersection for comfort ventilation purposes).

## 5. MANUFACTURER'S DESIGNATION OF THE FIRE DAMPER

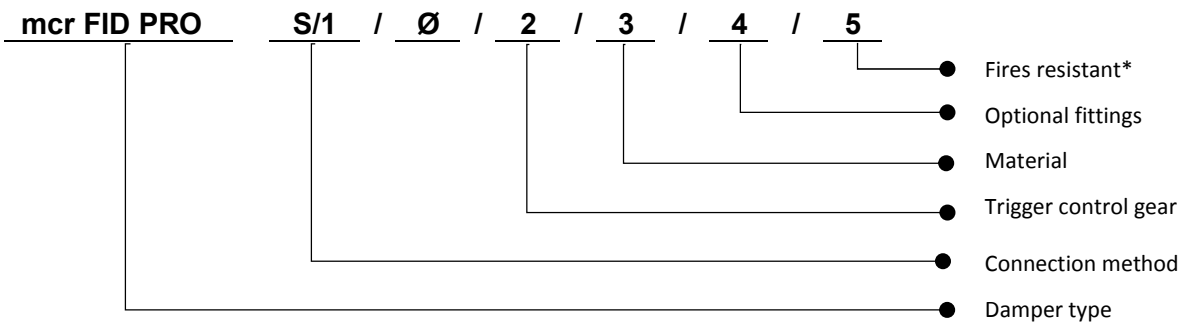

\* in the case of non-marking - by default EI120

## 6. INSTALLATION OF THE FIRE DAMPER

### NOTE

During the installation of a fire damper and while conducting finishing work, you should allow for the possibility of later access to the fire damper and removal of the release and control mechanism in order to carry out possible service work and technical inspections.

The mcr FID PRO fire dampers may be installed in the following space dividing elements (walls or structural floors):

- masonry/concrete walls with the minimum thickness of 120 mm
- brickwork walls or blockwork walls with the minimum thickness of 125 mm
- walls made of boards with the minimum thickness of 125 mm
- structural floors with the minimum thickness of 150 mm

Additionally, fire dampers may be installed:

- outside walls
- in dampers sets (multiple damper sets)

The mcr FID PRO fire dampers may also be installed in space dividing elements in buildings that have a lower fire-resistance rating. In such cases, fire dampers will have a fire-resistance rating equal to that of a space dividing element, with the condition of smoke leakage rating being satisfied. When installing a fire damper in a given type of wall which is thinner than required, its thickness should be increased along the perimeter of the fire damper, e.g. by installing an additional board or other building element.

### 6.1. PRE-INSTALLATION INSPECTION

Each fire damper is inspected by the manufacturer before packing and transport. Once the product has been unpacked at the destination, visual inspection should be conducted to check for possible deformations of the housing or fire damper transport damage.

# mcr FID PRO single-plane fire dampers

## 6.2. INSTALLATION OPENING

The minimum size of an installation opening necessary for correct installation of the fire damper is  $(D+40)$  mm. In the case of flange fire dampers, the minimum size of an installation opening is  $(D+80)$  mm. Light walls:  $\square A (D+40)$

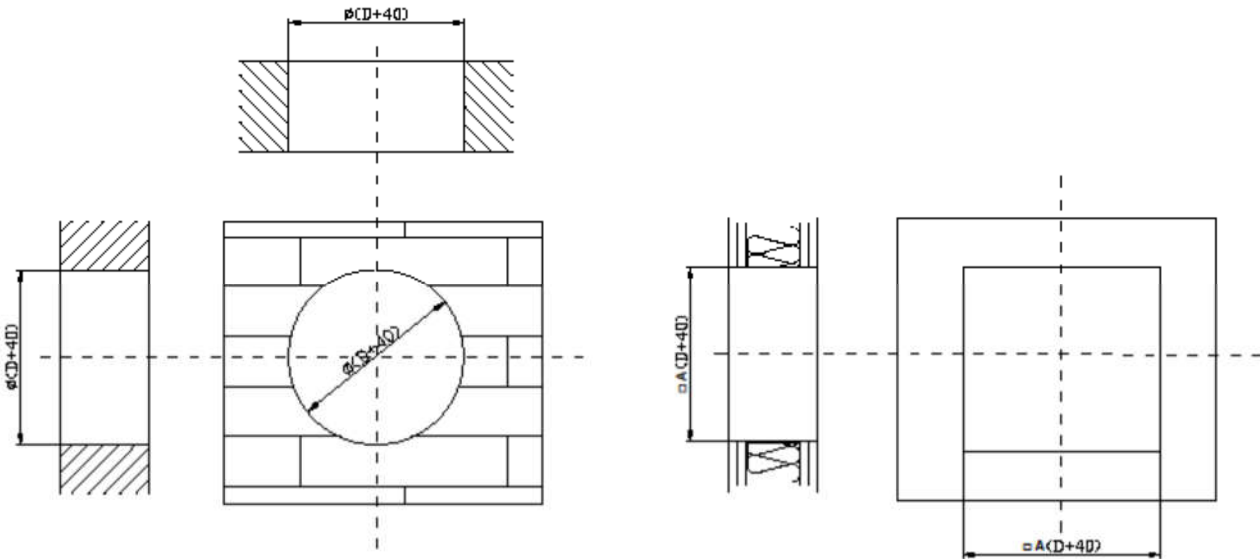

## 6.3. BUILDING IN (EMBEDDING) THE FIRE DAMPER

### NOTE

At least a 2.5 mm gap between the body and partition has to be ensured at each place along the fire damper perimeter. The fulfilment of this requirement is a prerequisite for product warranty.

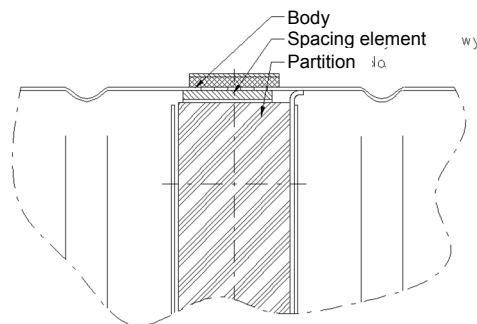

Ensuring an appropriate gap between the fire damper body and partition

The mcr FID PRO fire damper works correctly if the rotation axis of the partition is horizontal. The release and control mechanism may be located on the right or left of a fire damper irrespectively of the air flow direction. Installing a fire damper on its side, i.e. with rotation axes of the partition being vertical, is only permitted when this has been previously made known to the manufacturer at the time of placing the order.

Before building in/embedding, a fire damper should be placed axially in a space dividing element (a wall or structural floor that divides separate fire compartments), i.e. in a previously prepared opening. Next, level and secure the fire damper so that it does not move. Once the above have been completed, start manually the fire damper's partition, checking if it rotates correctly (it should not touch the housing elements, etc.). Close the fire damper's partition. The gap between the fire damper's housing and the wall should be completely filled with appropriate mixture which will provide the required fire-resistance rating of the wall and the fire damper. Moreover, special attention should be paid to ensure that the mixture does not come into contact with the equipment of the fire damper responsible for its proper operation (release and control mechanism, partition, seals and limiters). For this purpose, it is essential that you put plastic film or other material on the fire damper, which will protect it while masonry and finishing work is being carried out. The partition has to remain closed until the mixture sets. Once it has set, remove the brackets. Then, again open and close the fire damper in order to check if it works correctly. In the case of installation of a fire damper in a wall made of boards, the space between the fire damper's housing and the wall should be completely filled with A1 class non-flammable (certified) mineral wool. Its density and thickness should ensure fire-resistance not lower than that of the wall in which the fire damper has been installed. Additionally, the filled space should be sealed with an appropriate mixture or mastic having fire-resistance required by the wall.

In order to ensure fire-resistance of a fire separation, the depth to which it can be built in should never be exceeded, i.e. the rotation axis of the fire damper's partition cannot be outside the wall (off the wall surface). In the case of space



## mcr FID PRO single-plane fire dampers

dividing elements with a thickness comparable to that of a fire damper, it is recommended that the fire damper be installed in such a manner that its axis divides the thickness of the space dividing element precisely in half.

The installation of the fire damper off the wall shall be the exception to the above rule. If the fire damper is installed this way, a ventilation duct section between the fire damper's partition and fire separation shall be secured by means of fire-resistant boards or layers of mineral wool and structurally reinforced as recommended by the manufacturer of the solution. The fire resistance of the duct between the fire damper and the fire separation construction, should have a classification of not less than required for the fire damper and fire separation. The fire damper can be installed at a maximum distance of 1000mm from the fire zone space dividing elements.

The built-in fire damper has to be coaxially connected to a ventilation duct. When installing a fire damper, be sure that you do not damage its body, and in particular do not subject it to any stress. A fire damper cannot function as a "structural element" of a duct or ventilation system in which it has been installed. It is unacceptable to drill through the fire damper's housing, screw in bolts/screws and other elements that pierce through the housing towards the interior of the fire damper. Having connected the fire damper to a ventilation duct, check again if it works correctly.

When installing the mcr FID PRO fire dampers, ensure in particular that the thermal release (fusible component) is not damaged. It should not be exposed to high temperature (fire, welders, soldering irons) which causes its actuation (it is a component that has been designed to be used once only and will not be replaced under warranty). Similarly, the intumescent seals installed in the housing of the fire damper should not be exposed to high temperature. Expansion of the seals makes it impossible to close the fire damper. After the installation has been completed, clean thoroughly the fire damper and ensure that no debris has been left inside, as it could affect its correct operation.

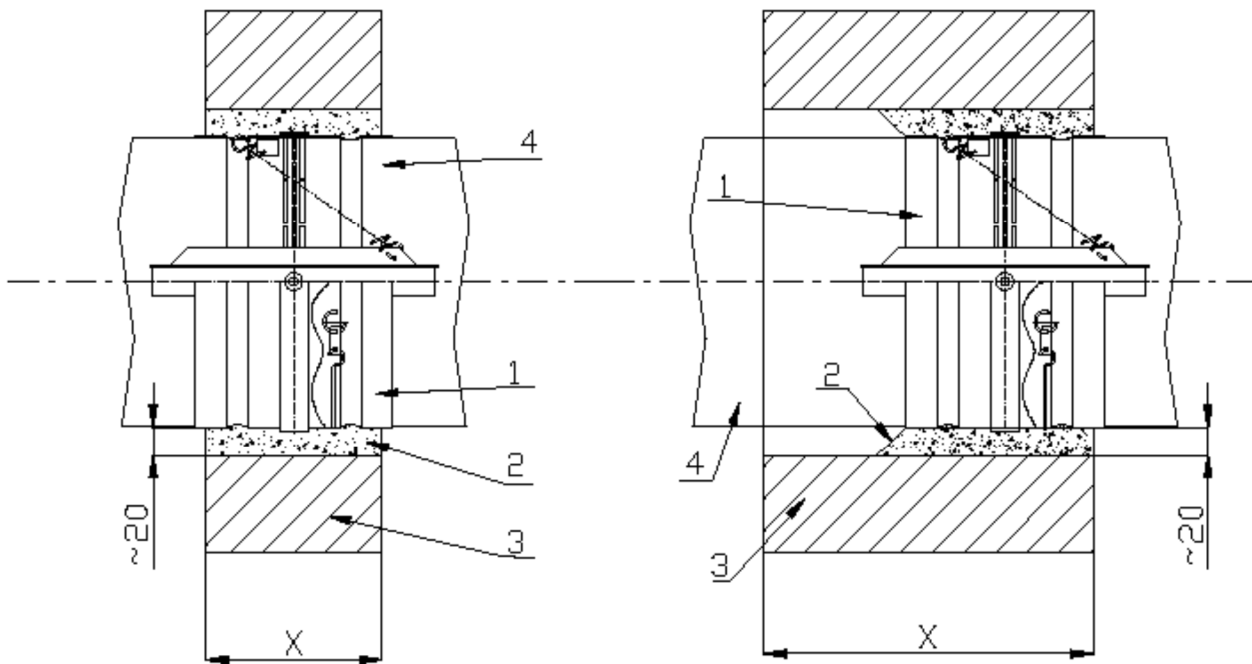

- 1. Fire damper
- 2. E.g. cement mortar

- 3. Wall
- 4. Ventilation duct

X – wall thickness

### Installation of the mcr FID PRO fire damper with a spring mechanism in masonry walls, brickwork walls or blockwork walls

# mcr FID PRO single-plane fire dampers

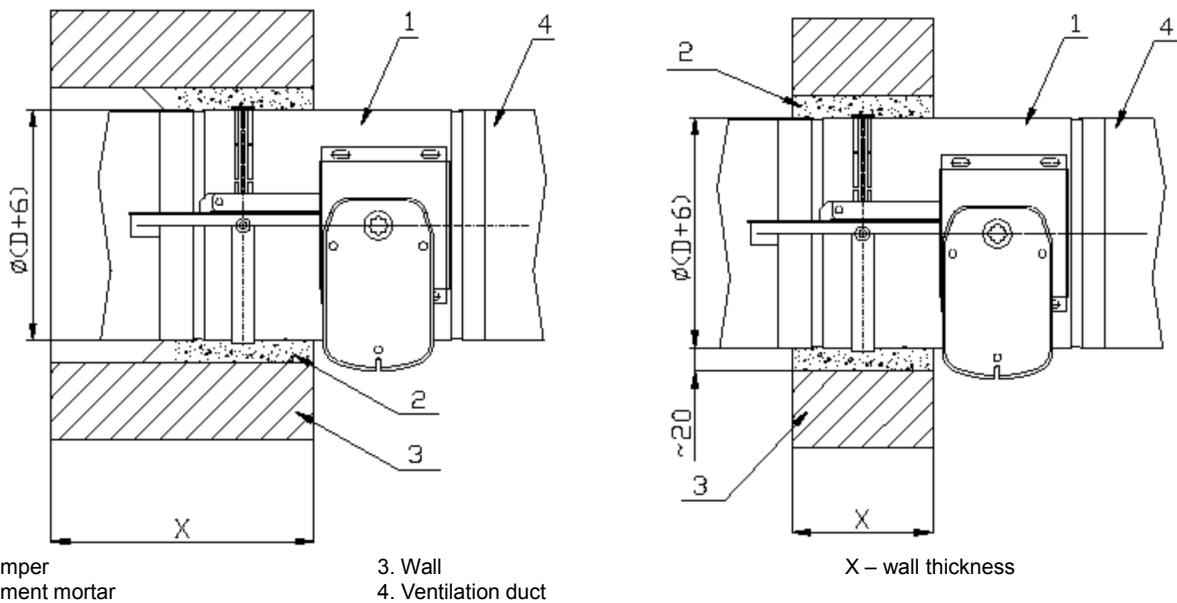

## Installation of the mcr FID PRO fire damper with an electric mechanism in masonry walls, brickwork walls or blockwork walls

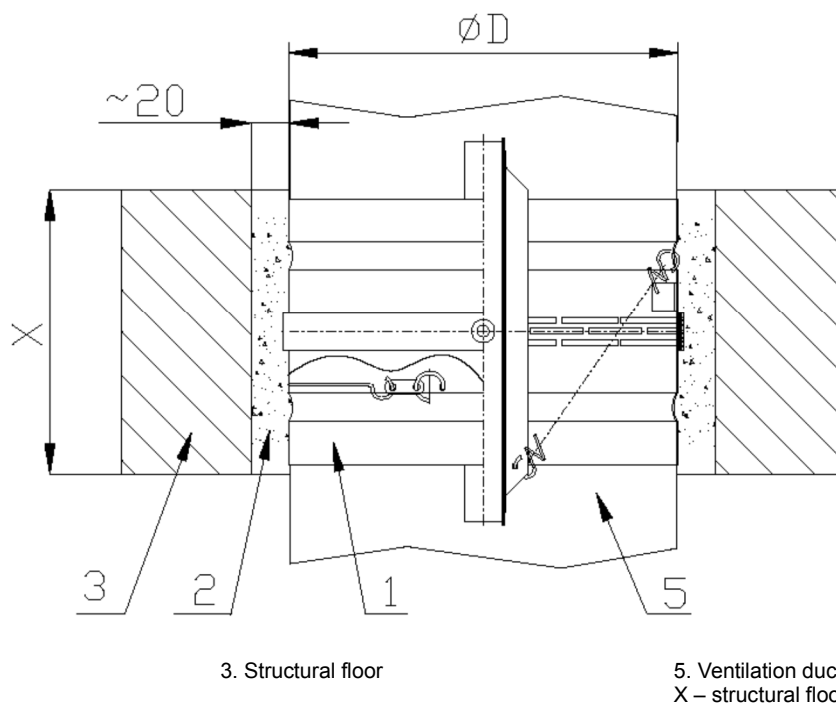

## Installation of the mcr FID PRO fire damper with a spring mechanism in structural floors

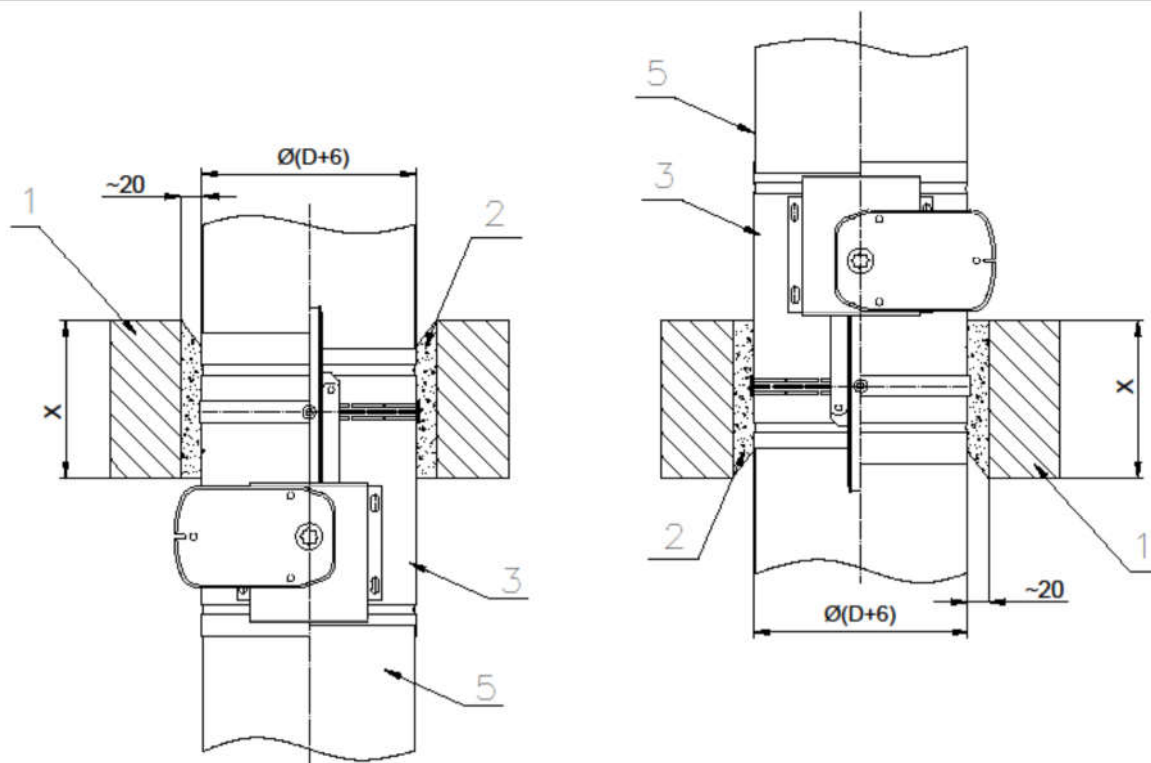

1. Structural floor  
2. E.g. cement mortar

3. Fire damper

5. Ventilation duct  
X – structural floor thickness

**Installation of the mcr FID PRO fire damper with an electric mechanism in structural floors**

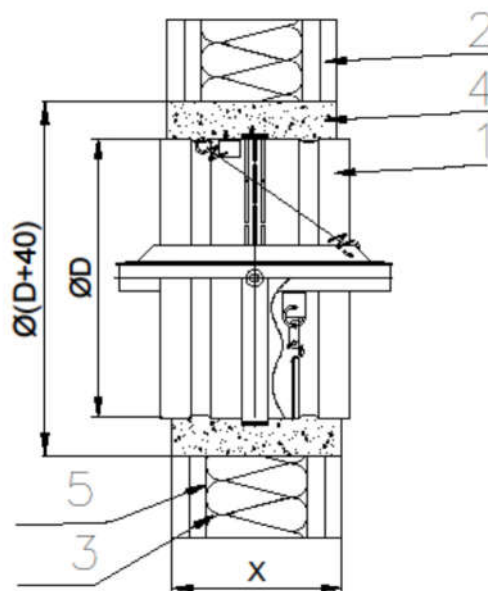

1. Fire damper  
2. Board, e.g. a fire-resistant gypsum board

3. Mineral wool, density: at least 80 kg/m<sup>3</sup>  
4. E.g. cement mortar

5. Structural section  
X – wall thickness

**Installation of the mcr FID PRO fire damper with a spring mechanism in walls made of boards**

# mcr FID PRO single-plane fire dampers

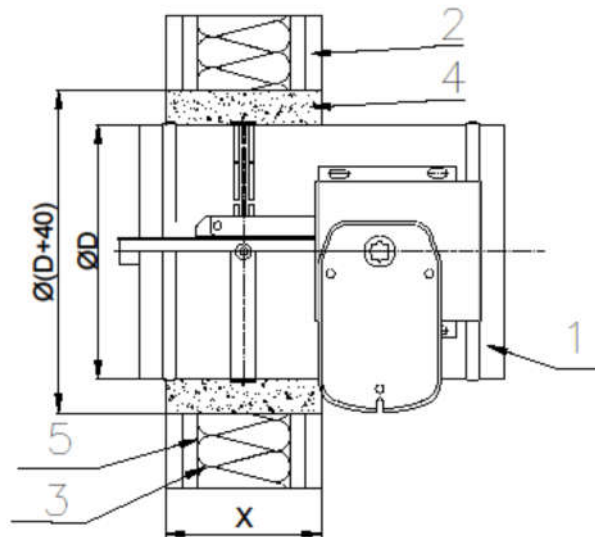

- 1. Fire damper
- 2. Board, e.g. a fire-resistant gypsum board
- 3. Mineral wool, density: at least 80 kg/m<sup>3</sup>
- 4. E.g. cement mortar
- 5. Structural section
- X – wall thickness

## Installation of the mcr FID PRO fire damper with an electric mechanism in walls made of boards

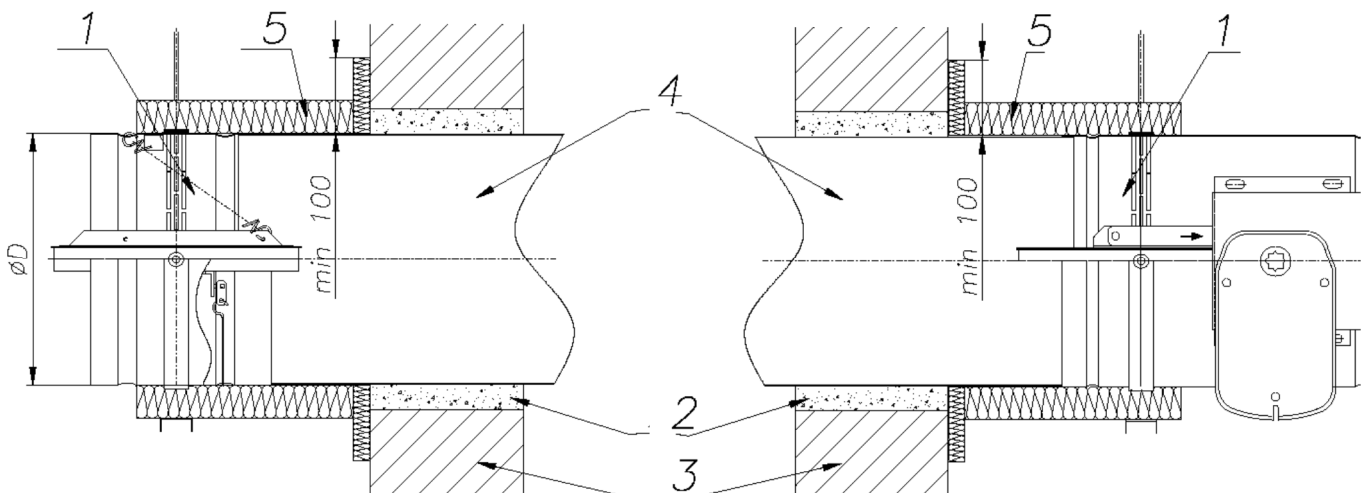

- 1. Fire damper
- 2. E.g. cement mortar
- 3. Wall
- 4. Ventilation duct
- 5. fire protection material at least EI120

## Example illustrating how to install the mcr FID PRO fire damper with a spring mechanism and electric mechanism off the wall

### 6.4. ELECTRICAL CONNECTIONS

Once a fire damper has been correctly installed, it is necessary to connect it to the electrical wiring system (using the wiring system's cables) if the fire damper is equipped with controls or other components that require such connection. Shown below are the wiring diagrams and basic electrical data of the release and control mechanisms supplied together with the mcr FID PRO fire dampers.

# mcr FID PRO single-plane fire dampers

## Electric actuators – electrical specification

Actuator type	Position of the fire damper's partition
– Belimo BFL range – Belimo BFN range – Belimo BF range – Mercor MLF range	Partition open – actuator indication 90° Partition closed – actuator indication 0°
– Belimo BE range – Belimo BLE range	Partition open – actuator indication 0° Partition closed – actuator indication 90°

Technical specification	MLF 24 (MLF24 T1)	MLF230 (MLF230 T1)	BF 24 (BF24-T)	BF230 (BF230-T)
Power supply	AC 24V 50/60Hz DC 24 V	AC 220-240V 50/60 Hz	AC 24V 50/60Hz DC 24V	AC 220-240V 50/60 Hz
Power demand:				
– when putting the spring under tension	7.2 W	7.2 W	7 W	8 W
– when in standby	2.5 W	2.5 W	2 W	3 W
Apparent power	10 VA	10 VA	10 VA	12.5 VA
Protection class	II	II	III	II
IP rating	IP 54	IP 54	IP 54	IP 54
Auxiliary switch:	2 x SPDT 6(1.5)A AC 250V	2 x SPDT 6(1.5)A AC 250V	2 x EPU 6(3) A, 250V	2 x EPU 6(3) A, 250V~
– activation point [degrees]	5°, 80°	5°, 80°	5°, 80°	5°, 80°
Torque:				
– motor	5 Nm	5 Nm	18 Nm	18 Nm
– spring	5 Nm	5 Nm	12 Nm	12 Nm
Wire connection:				
– motor (length: 0.9 m)	2 x 0.75 mm <sup>2</sup>	2 x 0.75 mm <sup>2</sup>	2 x 0.75 mm <sup>2</sup>	2 x 0.75 mm <sup>2</sup>
– auxiliary switch	6 x 0.75 mm <sup>2</sup>	6 x 0.75 mm <sup>2</sup>	6 x 0.75 mm <sup>2</sup>	6 x 0.75 mm <sup>2</sup>
Movement time: (0–90°)				
– motor	50–80 s	50–80 s	140 s	140 s
– return spring	≈20 s	≈20 s	≈16 s	≈16 s
Working temperature range	-30 ...+50°C	-30 ...+50°C	-30 ...+50°C	-30 ...+50°C
Sound pressure level:				
– motor	max. 45 dB (A)	max. 45 dB (A)	max. 45 dB (A)	max. 45 dB (A)
– spring	~ 62 dB (A)	~ 62 dB (A)	~ 62 dB (A)	~ 62 dB (A)

Technical data – actuators	BE24	BE230	BLE24	BLE230
Power supply	AC 24 V 50/60 Hz DC 24 V	AC 220–240 V 50/60 Hz	AC 24 V 50/60 Hz DC 24 V	AC 220-240V 50/60 Hz
Power demand:				
– when putting the spring under tension	12 W	8 W	7.5 W	5 W
– when in standby	0.5 W	0.5 W	0.5 W	1 W
Apparent power	18 VA	15 VA	9 VA	12 VA
Protection class	III	II	III	II
IP rating	IP 54	IP 54	IP 54	IP 54
auxiliary switch:	2 x SPDT	2 x SPDT 3 A AC 250 V	2 x SPDT 6(3) A, 250 V	2 x SPDT 6(3) A, 250 V~
– activation point [degrees]	3°, 87°	3°, 87°	3°, 87°	3°, 87°
Torque:				
- motor	40 Nm	40 Nm	15 Nm	15 Nm
- locking	50 Nm	50 Nm	20 Nm	20 Nm
Wire connection:				
– motor (length: 0.9 m)	3 x 0.75 mm <sup>2</sup>	3 x 0.75 mm <sup>2</sup>	3 x 0.75 mm <sup>2</sup>	3 x 0.75 mm <sup>2</sup>
– auxiliary switch	6 x 0.75 mm <sup>2</sup>	6 x 0.75 mm <sup>2</sup>	6 x 0.75 mm <sup>2</sup>	6 x 0.75 mm <sup>2</sup>
Movement time (0–90°):				
– motor	60 s	60	30 s	60 s
Working temperature range	-30 ...+50°C	-30 ...+50°C	-30 ...+50°C	-30 ...+50°C
Sound pressure level:				
– motor	max 62 dB (A)	max 62 dB (A)	max 62 dB (A)	max 55 dB (A)

Technical data – actuators	BFL24 (BFL24-T)	BFL230 (BFL230-T)	BFN24 (BFN24-T)	BFN230 (BFN230-T)
Power supply	AC 24 V 50/60 Hz DC 24 V	AC 220–240 V 50/60 Hz	AC 24 V 50/60 Hz DC 24 V	AC 220-240V 50/60 Hz
Power demand:				
– when putting the spring under tension	2.5 W	3.5 W	4 W	5 W
– when in standby	0.7 W	1.1 W	1.4 W	2.1 W
Apparent power	4 VA	6.5 VA	6 VA	10 VA
Protection class	III	II	III	II

# mcr FID PRO single-plane fire dampers

IP rating	IP 54	IP 54	IP 54	IP 54
auxiliary switch:	2 x PDT	2 x PDT	2 x SPDT	2 x SPDT
- activation point [degrees]	3(0.5) A AC 250V	3(0.5) A AC 250V	3(0.5) A, 250 V	3(0.5) A, 250 V
	5°, 80°	5°, 80°	5°, 80°	5°, 80°
Torque:				
- motor	4 Nm	4 Nm	9 Nm	9 Nm
- spring	3 Nm	3 Nm	7 Nm	7 Nm
Wire connection:				
- motor (length: 0.9 m)	2 x 0.75 mm <sup>2</sup>	2 x 0.75 mm <sup>2</sup>	2 x 0.75 mm <sup>2</sup>	2 x 0.75 mm <sup>2</sup>
- auxiliary switch	6 x 0.75 mm <sup>2</sup>	6 x 0.75 mm <sup>2</sup>	6 x 0.75 mm <sup>2</sup>	6 x 0.75 mm <sup>2</sup>
Movement time (0-90°):				
- motor	60 s	60	60 s	60 s
- return spring	≈ 20 s	≈ 20 s	≈ 20 s	≈ 20 s
Working temperature range	-30 ... +55°C	-30 ... +55°C	-30 ... +55°C	-30 ... +55°C
Sound pressure level:				
- motor	max 43 dB (A)	max 43 dB (A)	max 55 dB (A)	max 55 dB (A)
- spring	~ 62 dB (A)	~ 62 dB (A)	~ 67 dB (A)	~ 67 dB (A)

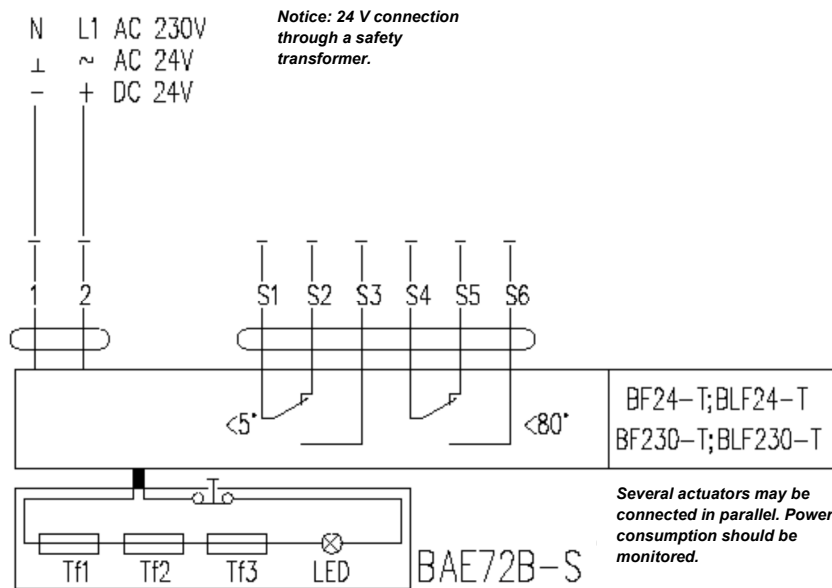

Wiring diagram for BF24-T, BLF24-T, BF230-T and BLF230-T actuators

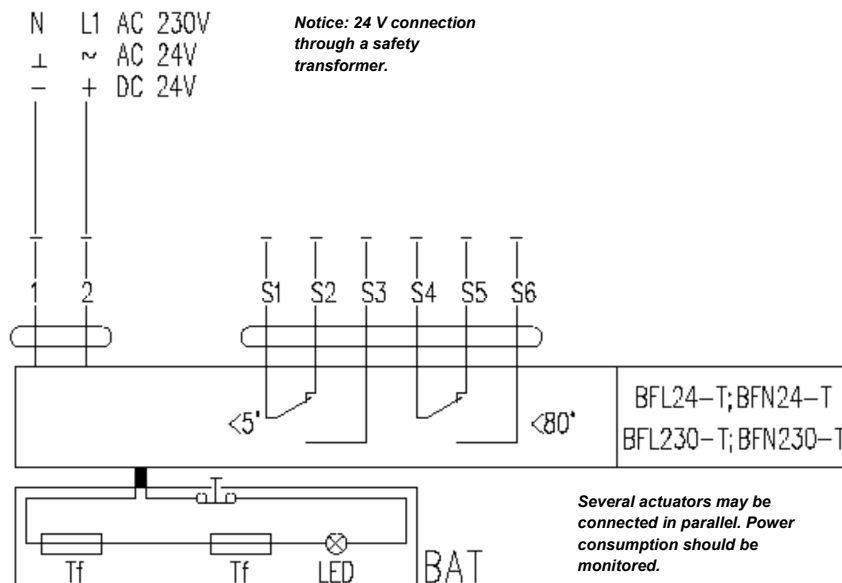

Wiring diagram for BFL24-T, BFL230-T, BFN24-T and BFN230-T actuators

# mcr FID PRO single-plane fire dampers

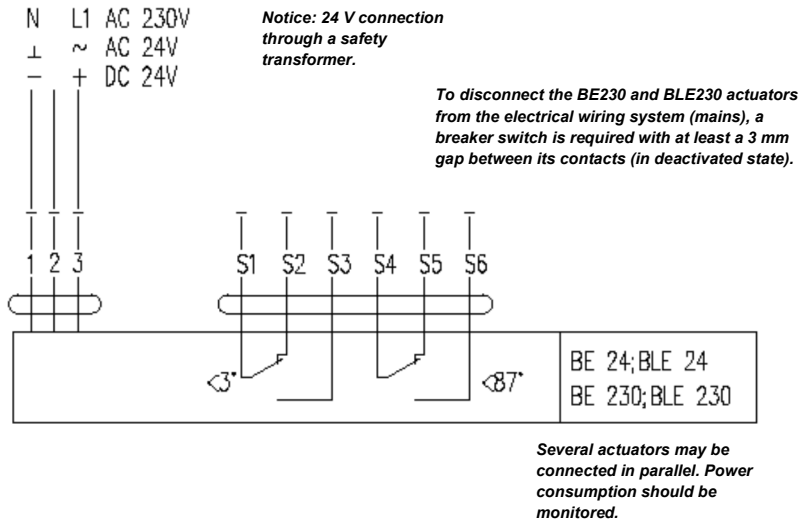

**Wiring diagram for BE24, BLE24, BE230 and BLE230 actuators**

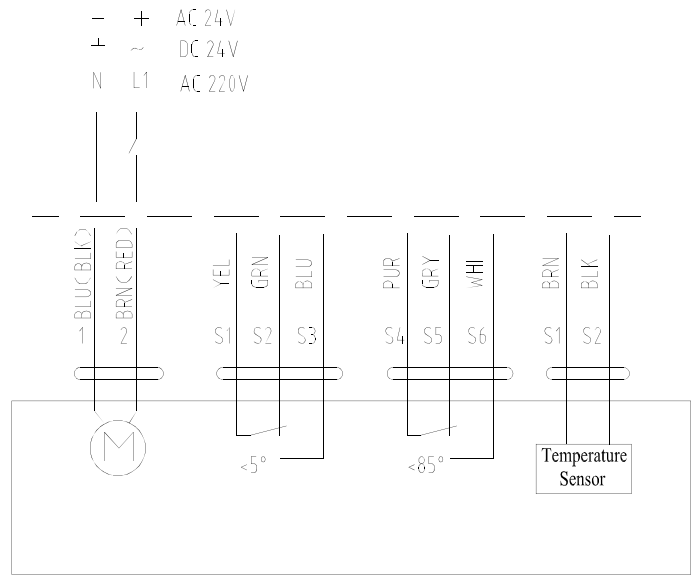

**Wiring diagram for MLF24 T1, MLF 230 T1.**

**Note:**

Controlling the operation of BE and BLE actuators requires connecting them to an electrical wiring system using three-wire cables. The change of rotation direction is effected by applying supply voltage to terminal 2 or 3, depending on the desired direction of rotation.

The position of limit switches for all actuator types applies to a potential free position.

For proper operation of a device equipped with electrical actuators, it is recommended that the rated voltage housed tolerance of 24V±10% or 230V±10%. Power supply devices other than listed above may cause malfunction and will not be covered by the warranty conditions.

**EXBF actuators**

Technical specification	EXBF 24	EXBF 230
Zone	1, 2, 21, 22	
ATEX class	II 2 GD EEx d IIC T6	
Power supply	24 V AC ±20% 50/60 Hz/24 VDC-10/+20%	230 V AC ±14% 50/60 Hz
Power demand:		
– when putting the spring under tension	7 W	8 W
– when in standby	2 W	3 W
Apparent power	10 VA	12.5 VA
IP rating	IP 66	IP 66
Auxiliary switch:	2 x SPDT 6A (3) max. 250 V AC	2 x SPDT 6A (3) max. 250 V AC

# mcr FID PRO single-plane fire dampers

– activation point	5°, 80°	5°, 80°
Torque:		
– motor	18 Nm	18 Nm
– spring	12 Nm	12 Nm
Movement time: (90°C)		
– motor	150 s	150 s
– return spring	≈20 s	≈20 s
Ambient temperature	-20 ...+50°C	-20 ...+50°C

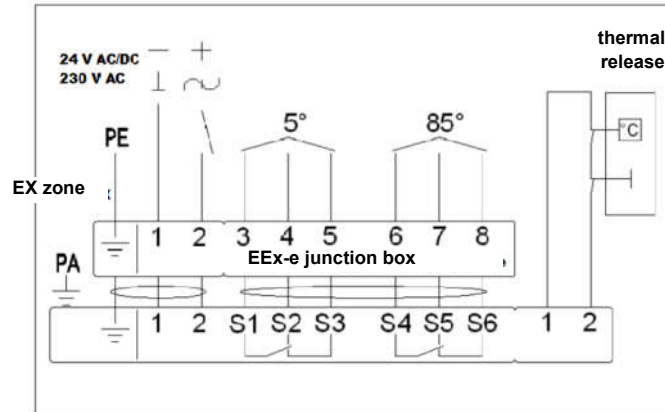

Wiring diagram for EXBF actuators

### Caution:

For proper operation of a device equipped with electrical actuators, it is recommended that the rated voltage housed tolerance of 24V±10% or 230V±10%. Power supply devices other than listed above may cause malfunction and will not be covered by the warranty conditions.

### RST/KW1 release and control mechanism

In the RST/KW1/S manufacturing version, the limit switches are installed on the mechanism itself. Electrical connection is carried out by connecting the wires (marked accordingly) to the electrical wiring system. The fusible release link is installed on the mechanism itself. The dampers with the RST/KW1/230I, RST/KW1/230P mechanisms, are supplied with the RST/KW1/24... triggering and control mechanism, together with the 230/24V transformer module MP230/24.

	RST/KW1/S	RST/KW1/24I	RST/KW1/24P	RST/KW1/230I	RST/KW1/230P
Supply voltage	X	24V–48V DC	24V–48V DC	230V AC	230V AC
Power consumption	X	3.5 W	1.6 W	4.5 W	2.5 W
Holding force	X	12 daN	12 daN	12 daN	12 daN
Thermal release actuation temperature	72°C ±2°C				
WK1d or WK2d limit switch	NO/NC (changeover switch) 5A, 230V AC				
Limit switches actuation	3°, 87°, ±2° tolerance				
Limit switches working temperature	-25 ...+85°C				
Electrical connection	X	– release: 0.6 m cable, 2 x 0.5 mm <sup>2</sup> – limit switch: 0.6 m cable, 6 x 0.5 mm <sup>2</sup>			
Rotation angle	92°				
Movement time	≤ 2 s (spring)				
Rotation direction	left				
Mechanism weight	1.2 kg	1.4 kg	1.4 kg	1.5 kg	1.5 kg

KW1 mechanism power supply	WK1 limit switch	WK2 limit switch
Wire no. 1–2	Wire no. 3–4, NO type (normally open)	Wire no. 6–7, NO type (normally open)
	Wire no. 4–5, NC type (normally closed)	Wire no. 7–8, NC type (normally closed)

### Note! The mechanism limit switches position has been provided for the safety position of the fire damper.

For proper operation of a device equipped with electrical actuators, it is recommended that the rated voltage housed tolerance of 24V±2% or 230V±2%. Power supply devices other than listed above may cause malfunction and will not be covered by the warranty conditions.



# mcr FID PRO single-plane fire dampers

## RST release and control mechanism

In the RST manufacturing version, limit switches are installed in the fire damper's housing as separate components. The fusible release link is installed on the fire damper's partition. The power spring is installed on the fire damper's partition.

To install the fusible release link in the RST manufacturing version:

- Put the fire damper's partition in the open position.
- Apply fusible link on the hooks attached to the body of the fire damper and partition.
- Remove the nut and lock the hook on the body of the fire damper by tightening up.

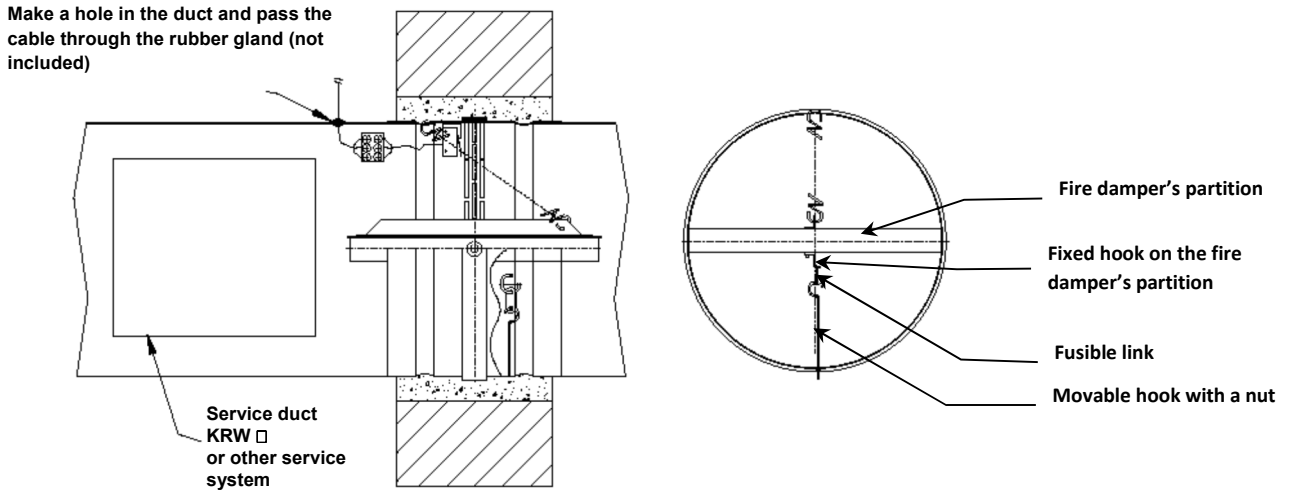

Separate limit switches of fire dampers – for the RST manufacturing version

WK1 – single limit switch – signalling of the closing of the fire damper's partition.

WK2 – a set of two limit switches – signalling of the closing and opening of the fire damper's partition.

### Technical data (limit switches)

WK1 and WK2 limit switches	1 x NO/1 x NC SPDT (changeover switch) 5A, 230V AC
Limit switches working temperature	-25 ...+85°C
Housing	plastic

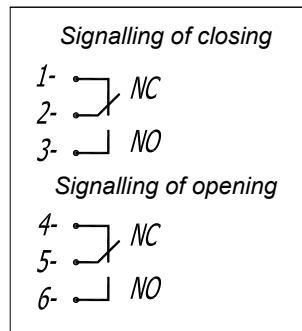

#### Note

When the partition is closed, the limit switch which signals the closing of the fire damper's partition is overridden (2–3 contact is closed).

WK1 and WK2 limit switches wiring diagram

## 7. TRANSPORT AND STORAGE CONDITIONS

Fire dampers are packed in cardboard boxes or placed on pallets. They are wrapped in plastic film or other protective material in order to protect them against damage. Fire dampers may be transported using any means of transport, provided that protection against the weather is ensured. Fire dampers placed on transport vehicles should be secured in such a way that they do not move during transport. Before installing fire dampers, conduct visual inspection of each unit. Do not move a fire damper by its connection cable or place it in such a way that its weight is supported on the release and control mechanism. Fire dampers cannot be hit or dropped. When moving and installing a fire damper, place it in such a way so that it is supported on its side panels or body edges.

Fire dampers should be stored in closed interior spaces which ensure protection against the weather. When fire dampers are stored on the floor, they should be placed on protective supports in order to protect them against damage.

# mcr FID PRO single-plane fire dampers

## 8. MAINTENANCE AND SERVICE (REPAIRS)

Products manufactured by „MERCOR” SA should undergo periodic technical inspections and maintenance at least every 12 months throughout their service life, i.e. in the warranty period and later. Inspections and maintenance should be carried out by the manufacturer or by companies authorised to service „MERCOR” SA's products.

The obligation to conduct regular inspections of fire equipment is stipulated in § 3 section 3 of the Regulation of Minister of Internal Affairs and Administration dated 7 June 2010 on the fire protection of buildings, other structures and areas (Dz. U. [Journal of Laws] 2010 No. 109, item 719).

The recommended operations to be carried out between the inspections are as follows:

- check the condition of electrical connections, paying particular attention to mechanical damage;
- Inspections of the condition of the supply voltage for the devices, which allowed the following tolerances:
  - 24V±10% for electric actuators
  - 24V±2% for electromagnetic release mechanism
  - 230V ±10% for electric actuators
  - 230V±2% for electromagnetic release mechanism
- check the condition of the fire damper's body, paying particular attention to mechanical damage;
- check for causes that could possibly affect the correct operation of the fire damper.

To enable full service inspections as well as servicing, including servicing under the warranty, such as visual inspections and repairs, the user has to ensure physical access to the product, e.g. by removing thermal insulation/suspended ceilings and disassembling other systems if they prevent free access to the product, etc.

In the case of fire dampers installed in ducts, it is recommended to make a service duct such as the mcr KRW type, for instance.

If devices are installed on the roof, ensure the possibility to enter the roof (ladder or lift).

For matters relating to technical inspections, maintenance and service of our products, please contact the Service Department of „Mercor” SA at [serwis@mercors.com.pl](mailto:serwis@mercors.com.pl), phone 058/ 341 42 45 (extension number 170), fax 058/341 39 85, 8 am–4 pm (Mon–Fri).

## 9. WARRANTY TERMS AND CONDITIONS

1. „MERCOR” SA gives a 12-month quality warranty for the products and, unless an agreement provides otherwise, the warranty period begins on the day of purchase.
2. Should physical defects be identified in the warranty period, „MERCOR” SA undertakes to rectify them no later than 21 days from the receipt of a written complaint and a proof of purchase or agreement, subject to item 6.
3. „MERCOR” SA reserves the right to extend the repair time in the case of complex repairs or those necessitating a purchase of non-standard components or spare parts.
4. Liability in respect of warranty shall only cover defects arising from causes originating in the sold products themselves.
5. In the event of defects due to improper operation of products or other reasons indicated in item 6, the purchaser/warranty holder shall bear the cost of removing such defects.
6. The warranty shall not cover any of the following:
  - Damage and failures of products caused by improper use, user's tampering with product and lack of periodic technical inspections/maintenance described in the “MAINTENANCE AND SERVICE (REPAIRS)” section of this document.
  - Damage of products due to other causes than those attributable to „MERCOR” SA, in particular fortuitous events such as torrential rain, flood, hurricane, flooding, strike of lightning, mains overvoltage, explosion, hail, aircraft crash, fire, avalanche, landslide and secondary damage resulting from the above causes. Torrential rain shall mean rain with rainfall intensity of at least 4, as determined by IMiGW [Institute of Meteorology and Water Management]. If rainfall intensity cannot be determined, the actual conditions and extent of damage at the place of damage, proving the event of torrential rain, shall be taken into consideration. Hurricane shall mean wind speed of at least 17.5 m/s (damage shall be deemed to be caused by a hurricane if hurricane is proven to have occurred in the proximity).
  - Damage caused as a result of failing to report immediately a discovered defect.
  - Deterioration of the quality of coating caused by natural ageing processes.
  - Defects caused by the use of abrasive or corrosive cleaning agents.
  - Damage caused by aggressive external agents, especially chemical and biological, or such agents whose origin is related to the production processes and activities carried out in a facility or its immediate proximity where the products have been installed.
  - Parts subject to normal wear and tear during operation (e.g. seals) unless they are found to have manufacturing defects.
  - Defects caused by improper transport, unloading or storage of the product.

## **mcr FID PRO** single-plane fire dampers

---

- Defects caused by installing the product in a manner inconsistent with this OMM and good building practice.
  - Products or parts thereof if the data plate/warranty seals have been torn off or damaged.
7. A warranty complaint shall be sent to „MERCOR” SA within 7 days from the date of discovering a defect.
  8. Warranty complaints may be lodged by dialling 58/341-42-45, sent by fax to 58/341-39-85 or by email: reklamacje@mercor.com.pl . Complaints may also be sent to the following postal address: „MERCOR” SA, ul. Grzegorza z Sanoka 2, 80-408 Gdańsk.
  9. The buyer/warranty holder shall use the products as instructed and carry out periodic technical inspections and maintenance in accordance with the rules set out in the “MAINTENANCE AND SERVICE (REPAIRS)” section of this document.
  10. The warranty shall become void immediately in the following cases:
    - If the buyer/warranty holder makes any modifications to the original design on their own, i.e. without consulting „MERCOR” SA beforehand.
    - If the periodic technical inspections and maintenance are not carried out in time or are carried out by unauthorised persons or personnel of service stations not authorised by „MERCOR” SA, or if the product have been used improperly.
    - If any tampering by unauthorised persons has been performed, except for the normal course of use of the products.
  11. In the cases referred to in item 10, the liability of „MERCOR” SA under statutory warranty shall be excluded.
  12. The condition for removal of defects is the complaining party’s making available full access to the products in order to conduct the work, in particular free access to interior spaces where the products have been installed and making available the necessary service ducts, removing thermal insulation/suspended ceilings as well as disassembling other systems if they prevent free access to the products, etc.

*Relevant provisions of the Civil Code shall apply to matters not governed by these warranty terms and conditions.*