

OPERATION AND MAINTENANCE MANUAL

Air fire damper **FS**



Version FS 19.06.27.6

FIRE VENTILATION SYSTEMS DEPARTMENT

TABLE OF CONTENTS:

1. INTRODUCTION	3
2. SUBJECT MATTER OF THE MANUAL	3
3. INTENDED USE OF THE DEVICE	3
4. DESIGN AND OPERATING PRINCIPLE OF THE DEVICE	4
5. DAMPER MARKING	5
6. DEVICE ASSEMBLY	6
6.1. INSPECTION BEFORE THE ASSEMBLY	6
6.2. ASSEMBLY	6
6.3. ELECTRICAL CONNECTIONS	8
7. TRANSPORT AND STORAGE CONDITIONS	11
8. MAINTENANCE AND SERVICING	11
9. WARRANTY TERMS	12

1.

INTRODUCTION

The purpose of this operation and maintenance manual is to acquaint the user with the intended use, design, operating principle, correct installation and operation of the product.

The manual also includes additional information about the operating conditions, maintenance and warranty terms for the product.

The manual below applies to the entire group of FS-type (FireShield) fire dampers. Observing recommendations included in the manual ensures proper functioning of the device in terms of fire protection of rooms as well as safety of the system users.

NOTE

On the date of publication of the operation and maintenance manual, the previous versions are no longer valid.

The operation and maintenance manual does not apply to the dampers manufactured before the date of its publication.

2. SUBJECT MATTER OF THE MANUAL

The subject matter of this operation and maintenance manual are:

- FS/IF dampers for embedding in rigid partitions
 - 101 square or rectangular
 - 201 square or rectangular
 - 301 circular
- FS/DWFX-C dampers for embedding in new light walls
 - 101 square or rectangular
 - 201 square or rectangular
 - 301 circular
- FS/DWFX-F dampers for embedding in existing light walls
 - 101 square or rectangular
 - 201 square or rectangular
 - 301 circular

3. INTENDED USE OF THE DEVICE

Application

Fire dampers with heat-sensitive trips are intended for use in vertical partitions in order to allow for air passage. The dampers' function is to maintain the fire resistance of the partition in which they are mounted. During normal operation, the dampers are open. Closing of the dampers proceeds automatically due to the activation of the heat-sensitive or electromagnetic trip. The FS fire dampers applied in systems protecting escape routes from smoke migration remain open during fire, thus supplying fresh air to the escape routes. If the fire spreads, the fire dampers close automatically due to the activation of the heat-sensitive trips, thus preventing the spread of fire through the vertical escape routes.

The damper may not work in installations susceptible to dust, unless it is included in a special, individually developed servicing and technical inspection programme.

Fire resistance

FS/IF damper – E120 ($h_o v_e i \leftrightarrow o$)

FS/DWFX-C damper – E120 ($v_e i \leftrightarrow o$)

FS/DWFX-F damper – E120 ($v_e i \leftrightarrow o$)

Versions

- 101 with the curtain partially in the airstream
- 201 with the curtain out of the airstream
- 301 with the round connection

4. DESIGN AND OPERATING PRINCIPLE OF THE DEVICE

Design

The FS damper consists of a double casing in the rectangular cross-section, movable shut-off partition in the form of a descending folded curtain and tripping control mechanism (cassette) activated remotely or automatically once the heat-sensitive trip is initiated. The damper casing is made of galvanised steel sheet. The total casing length is 90 mm (rectangular) and 92 mm (circular). Each damper has, on both sides, a connection stub 38 mm (rectangular) and 60 mm long (circular). The shut-off partition is made of stainless steel sheet.

On the inner side of the casing, there is a steel flat bar of elastic sheet, which additionally seals the device after its activation. The partition is moved by tape springs located on both sides of the damper.

Operation

In the normal position, the dampers are open. The dampers are set to the safety mode (closed):

- Automatically, through the initiation of the fusible link 72°C
- Manually, through the release of the manual release handle (tripping control mechanism)
- Remotely, through the EM (electro-magnetic) trip initiation

The dampers with the EM release devices close due to the shut-off of current supply, due to the actuation of the spring return mechanism in the damper. The dampers open after feeding supply voltage to the release device and after manual lifting of the steel partition.

The dampers with the tripping control fusible mechanism close due to the operation of the power spring in the damper, activated through the initiation of the fusible link, or manually through the tripping handle. Opening of the dampers occurs manually through lifting the steel partition and locking it in the holders of the releasing control mechanism.

NOTE

On no account should you tug the partition in order to close it.

Drive and tripping systems

The drive system of the FS dampers consists of two tape springs located on the inside of the damper sides, along its height. Exceeding the permissible temperature in the cassette causes the tripping control mechanism to be released and the partition driven by the springs to be lowered. It is possible to provide the damper with the EM mechanism (described at point 6.4) intended for the remote damper operation.

Dimensions

The FS-type fire dampers are manufactured in the following dimensions.

- Series 101 (fig. 1) – from 100 x 100 to 1,250 x 1,000 mm
- Series 201 (fig. 2) – from 100 x 250 to 1,250 x 1,000 mm
- Series 301 (fig. 3) – from D100 to D1,000 mm

Aside from the standard dimensions, there is a possibility of manufacturing dampers with intermediate dimensions.

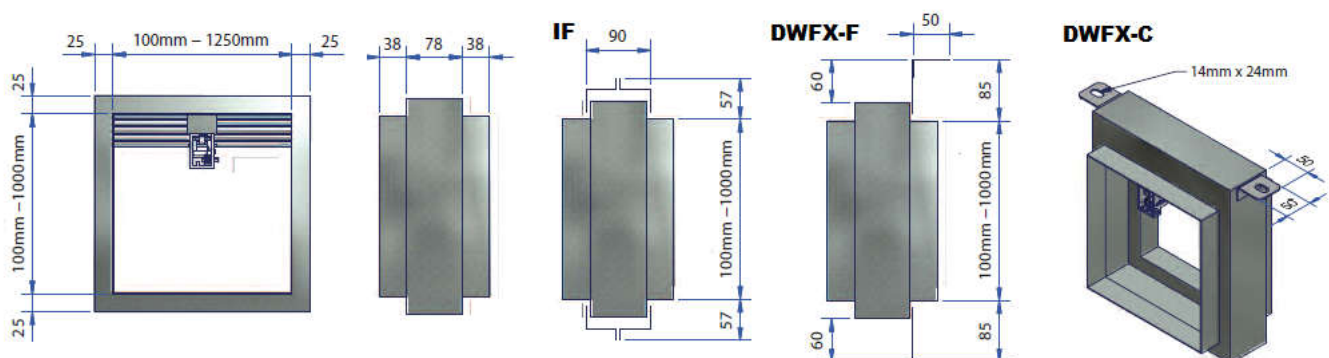

Figure 1. Series 101 with the curtain partially in the airstream

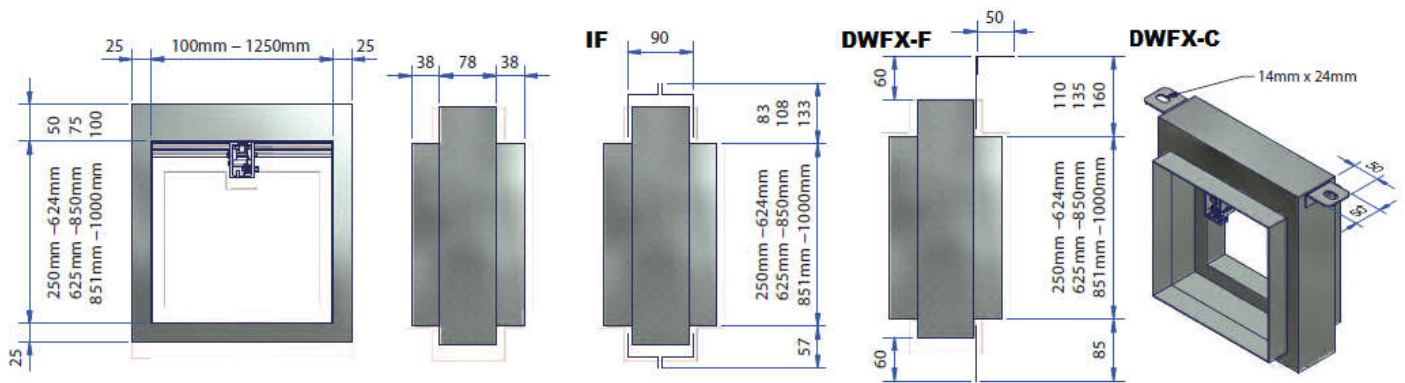

Figure 2. Series 201 with the curtain out of the airstream

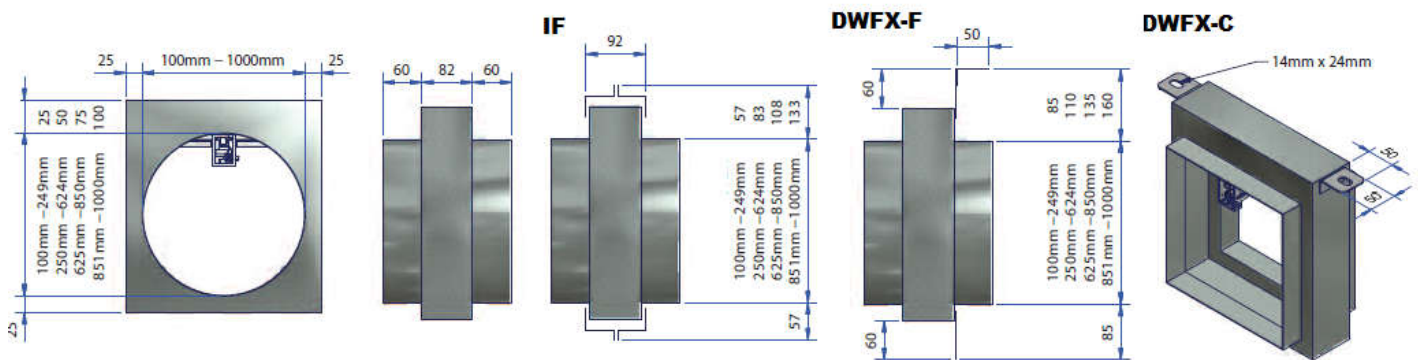

Figure 3. Series 301 with the curtain out of the airstream

5. DAMPER MARKING

FS 201	/	400 (W) x 400 (H)	/	IF	
					Accessories
					Dimensions of the working opening
					Damper type

type:

- FS 101 – square or rectangular with the curtain partially in the airstream
- FS 201 – square or rectangular with the curtain out of the airstream
- FS 301 – circular with the curtain out of the airstream

accessories:

- IF – installation frame for rigid partitions
- DWFX-C – frame for mounting before embedding in dry partition walls
- DWFX-F – frame for existing dry partition walls
- MSSP – single switch (closed damper indication)
- MSDP – two single switches (closed and open damper indication)
- EM 24 – electromagnetic release device (supply voltage 24 V AC/DC)
- EM 240 – electromagnetic release device (supply voltage 230 V AC)

6. DEVICE ASSEMBLY

NOTE

Install and finish the damper in such a manner as to provide access to it in future and enable the disassembly of the tripping control mechanism, in order to perform any servicing works and technical inspections.

6.1. INSPECTION BEFORE THE ASSEMBLY

Each damper is inspected before packaging and transporting by the manufacturer. After unpacking at the consignee's site, visually inspect whether the casing has not been deformed or whether the damper has not been damaged while in transport.

6.2. ASSEMBLY

IF VERSION ASSEMBLY (fig. 4)

1. In the upper part of the opening (lintel), drill the holes and attach steel anchors to the lintel (min. dimensions of the attachments 6,5 mm x 60 mm).
2. Level the damper, inserting wood blocks or slabs at the bottom, which blocks and slabs are removable after bonding the mortar.
3. Using a steel wire, attach the steel "tails" of the frame with the anchors in the mounting hole.
4. Apply mortar on both sides, filling in the frame space, taking care that the mortar does not soil the connection cuff.
5. According to EN 1366-2, the minimum clearance between the fire dampers installed in separate ducts should be at least 200 mm.

DWFX-C VERSION ASSEMBLY (fig. 5)

1. In the place of assembly, erect the wall after mounting the damper in the ceiling.
2. Attach the damper by use of threaded pins-rods M10 to the ceiling in the middle of the damper.
3. Attach the mounting profiles and tighten the gypsum board.
4. Insulate it with mineral wool.
5. Seal both sides of the damper.
6. Finish the wall by the standard practice.
7. According to EN 1366-2, the minimum partition between the fire dampers installed in separate ducts should be at least 200 mm.

DWFX-F VERSION ASSEMBLY (fig. 6)

1. Measure the damper dimensions without the installation frame.
2. Determine the size of the ready opening by adding $25 \text{ mm} \pm 5 \text{ mm}$ + two board thicknesses to the width and height.
3. Mark the opening in the gypsum board and cut it out, maintaining stability and rigidity of the gypsum board.
4. Prepare holes in the damper flange every 150 mm in such places for the screws to penetrate the profile around the opening.
5. Mount and tighten the damper.
6. On the other side, fill in the slot with mineral wool up to the stub and mount a band around the damper.
7. According to EN 1366-2, the minimum clearance between the fire dampers installed in separate ducts should be at least 200 mm.

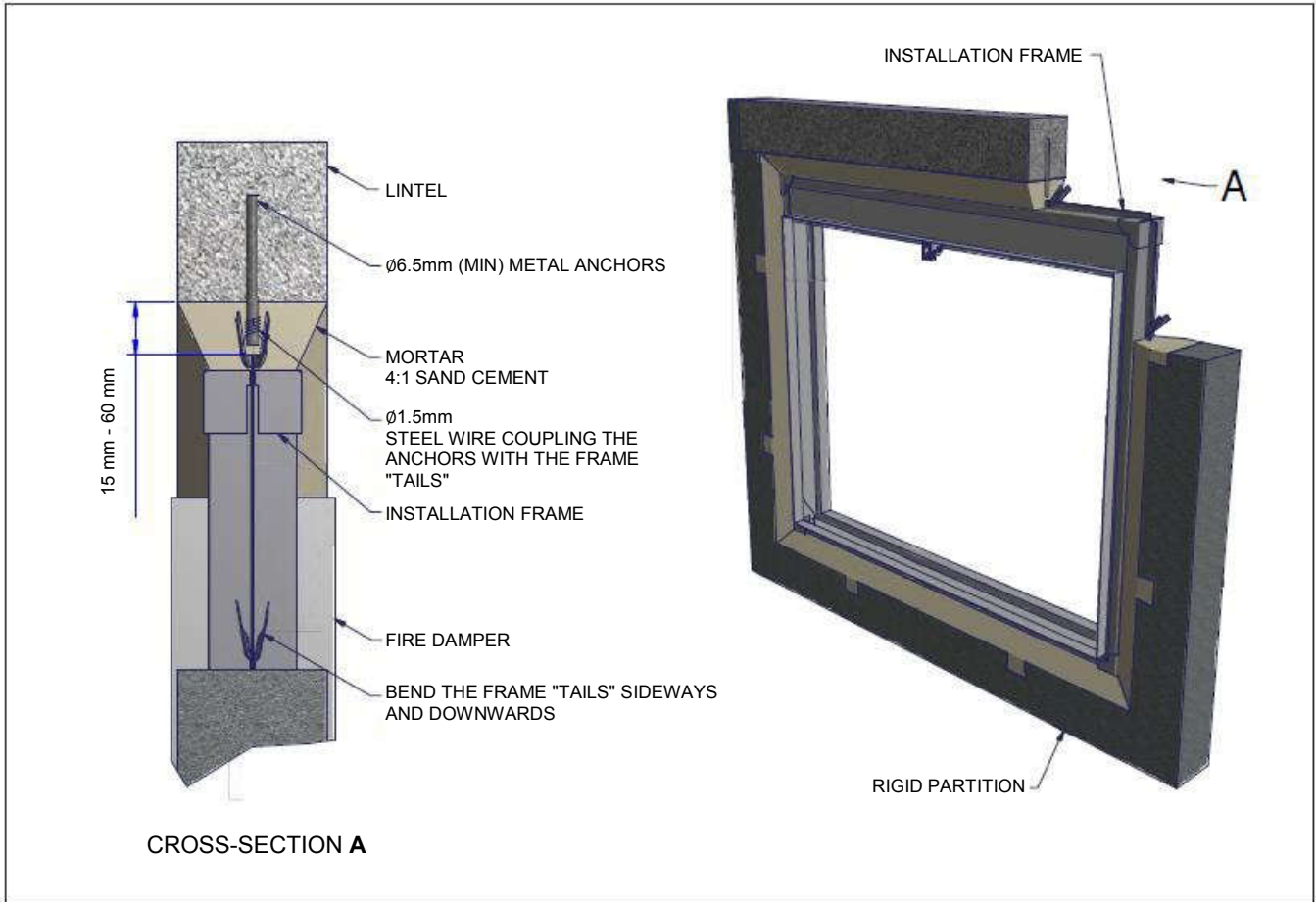

Figure 4. IF version assembly.

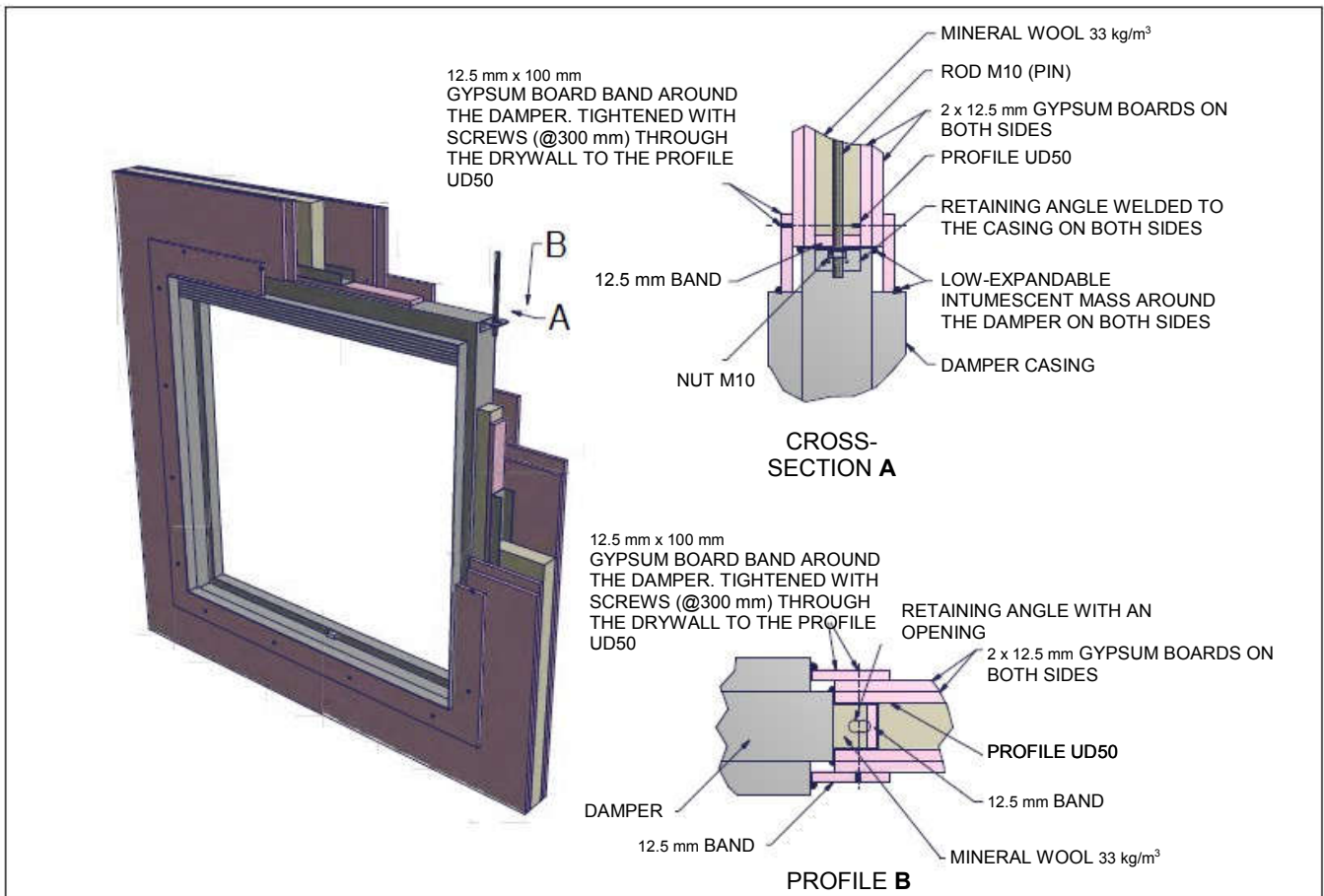

Figure 5. DWFX-C version assembly.

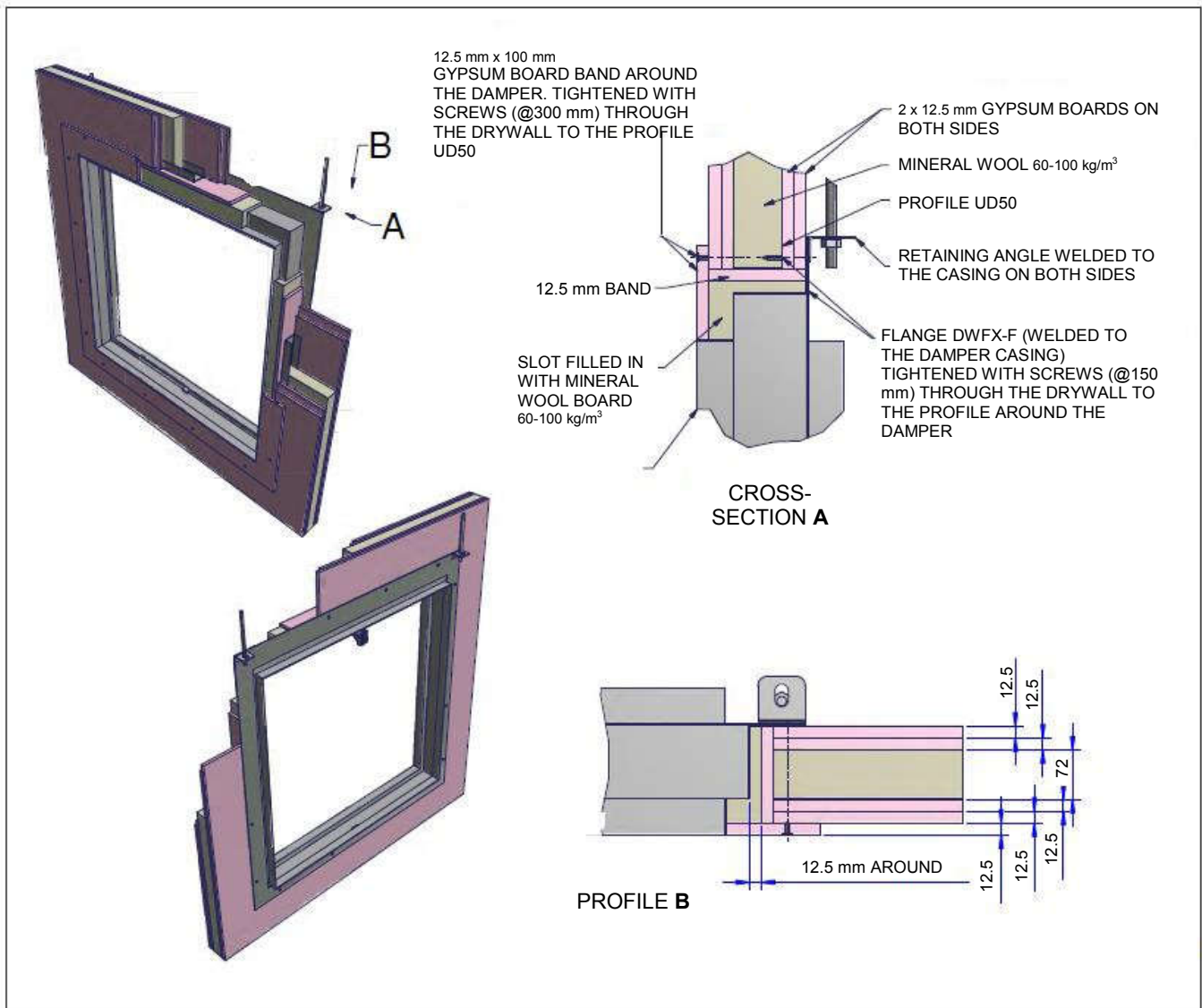

Figure 6. DWFX-F version assembly.

The damper can be mounted only in the position where the curtain (fire partition) descends (tripping control mechanism on top of the damper). In order to provide a sufficient fire-resistance rating of the fire separation, mandatorily observe the embedding limit – the damper partition axis may not be located out of the wall. In partitions characterised by the thickness comparable with the thickness of the damper, it is recommended mounting the damper in such a manner as for its axis to be located right in the middle of it. During the installation works, do not allow any damage to the damper body, in particular – do not allow any stresses in the body. Drilling through the damper casing, tightening screws, bolts and other such elements penetrating the casing, and further – reaching inside the damper, is unacceptable.

While mounting the FS damper, the heat-sensitive trip (fusible link, in the cassette on top of the device) should be secured against mechanical damage and high temperatures (fire, welding, soldering), which cause its initiation (it is not a reusable resettable link and is not replaced within the framework of the warranty).

6.4. ELECTRICAL CONNECTIONS

After correct embedding of the damper, if it has control elements or other elements that require connecting the electrical installation, connect the cords of this installation to the damper. Below are presented wiring diagrams and basic electrical data of the tripping control mechanism delivered with the FS dampers.

EM tripping control mechanism

The EM mechanism is intended for the operation of the FS-type fire dampers. After disabling the supply voltage, the mechanism lock is released, setting the steel wire in motion and causing the damper to activate. The mechanism does not have a power (return) spring. This spring is mounted directly on the damper.

Variations:

- EM24 – mechanism powered by the voltage of 24 V AC/DC –tripping by the loss of supply voltage (fig. 7a)
- EM240 – mechanism powered by the voltage of 230 V AC/DC –tripping by the loss of supply voltage (fig. 7b)

	EM24	EM240
Power supply voltage	24 V AC/DC	230 V AC 50 Hz
Rated current	120 mA	10 mA
Electrical connection	Cable 3 x 0.75 mm ²	
Weight	1.6 kg	1.6 kg

EM mechanism supply:

- Brown conductor – power supply "+" or "L"
- Blue conductor – mass "-" or "N"
- Green and yellow conductor – earthing "E"

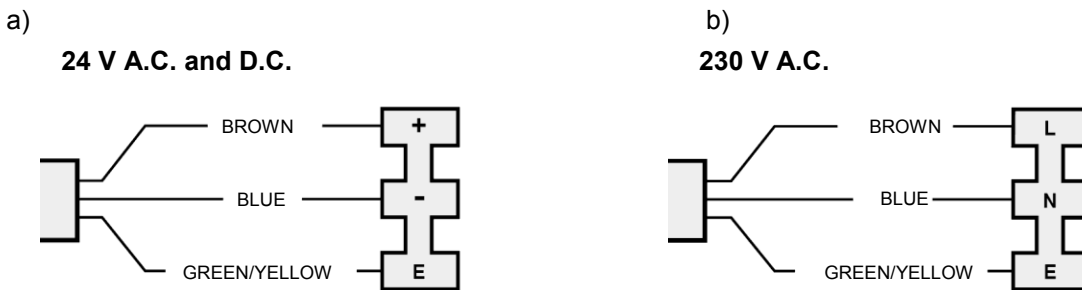

Figure 7. EM mechanism supply: a) with the voltage of 24 V AC/DC; b) with the voltage of 230 V AC 50 Hz

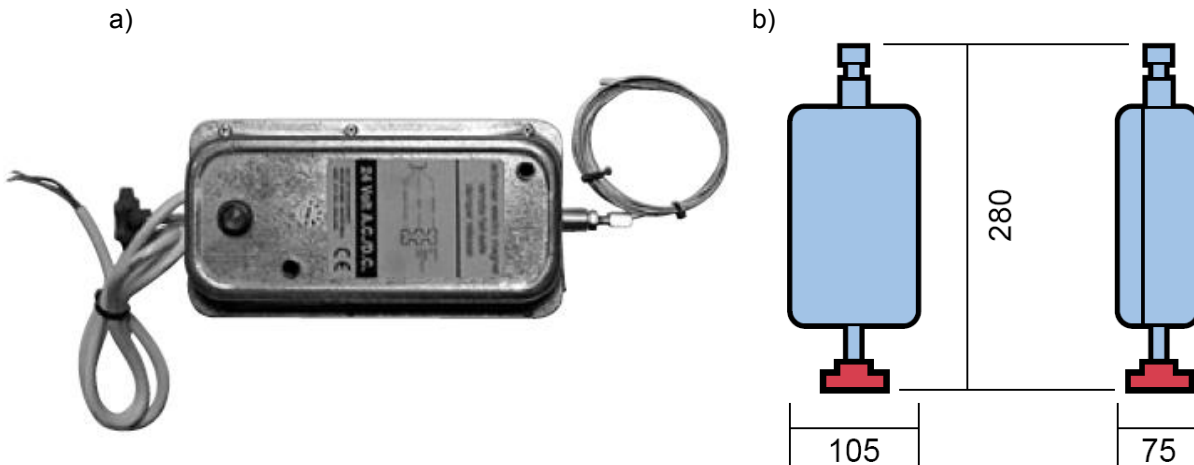

Figure 8. EM mechanism a) actual image b) dimensions

While installing the electromagnetic release device:

- drill the opening in the damper flange in order to allow for its penetration by the release device wire.
- in the releasing cassette, push the wire, respectively, through openings 1 and 2 marked in figure 9. The end of the release device wire is equipped with the counter screw, which is to be demounted before assembly. Having pushed the wire through the holes, the counter screw is locked again.



Figure 9. Electromagnetic release device cassette.

During the assembly operations, the damper should be in the closed position. The electromagnetic release device should be located outside the duct, near the damper. The release device wire may not be twisted nor coiled. If the wire is too long, it can be shortened.

If the release device is live, the damper should be armed. "disabling" the voltage causes the damper to trip. After its activation, the damper should be set to the starting position by lifting its partition manually.

Limit switches

The FS damper may also be delivered with MSSP- or MSDP-type limit switches. The limit switches are mounted on the damper casing as independent devices.

Variations:

MSSP – single switch – closed damper partition indication.

MSDP – unit of two single switches – closed and open damper partition indication.

MSSP and MSDP limit switches	1NO/1NC SPDT (changeover contact)
Limit switch working temperature	-25°C to +85°C
Service life	5,000,000 cycles
Voltage	300 V AC and 250 V DC
Current	10 A
Head execution	"Whisker" or "steel rod"
Ingress protection	IP66

Electrical wiring diagram of the limit switches

MSSP – one limit switch indicating that the damper is closed

MSDP – two limit switches

- contacts 13 and 14 NO (normally open)
- contacts 21 and 22 NC (normally closed)

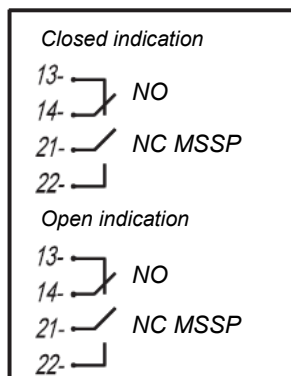

Caution

The layout of the mechanism limit switches apply to the safety position of the damper

Figure 10. Wiring diagram for the limit switches in the FS damper

a)

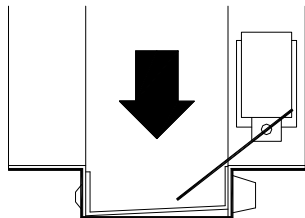

b)

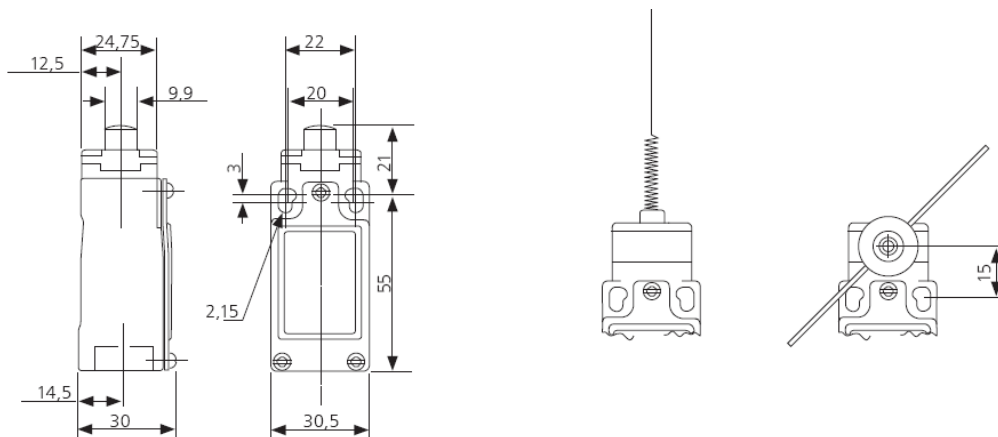

Figure 11. MSSP switch a) location of the switch in the damper b) limit switch dimensions.

7. TRANSPORT AND STORAGE CONDITIONS

The FS fire dampers are packed in cardboard boxes or on pallets. The dampers are protected against damage by film or another covering material. Their transport may take place by any means, provided that they are protected against weather conditions. The dampers placed on means of transport should be secured against dislocation while in transport. After every transport, visually inspect every damper. Do not hit nor drop the damper. While transporting and mounting, take care of the damper partition.

The dampers should be stored in closed rooms that provide protection against external weather conditions. If dampers are stored on the ground, place them on protection pads in order to secure them against damage.

8. MAINTENANCE AND SERVICING

„MERCOR” S.A. devices should undergo periodical technical inspections and maintenance works, no less than every 12 months during the entire operation period, that is during the warranty period and afterwards. Inspections and maintenance works should be carried out by the manufacturer or by companies that have the authorisation for servicing „MERCOR” S.A. devices.

The obligation to carry out regular service inspections of fire protection devices arises from Art. 3(3) of Regulation of the Minister of Internal Affairs and Administration of 7 June 2010 on fire protection of buildings, other civil structures and areas (Journal of Laws 2010 no. 109, item 719).

It is recommended that the following actions be performed between inspections:

- Checks of the condition of electrical connections, taking the account of mechanical damage in particular.
- Checks of the device body, taking the account of mechanical damage in particular.
- Checks whether there are any obstacles which could influence the correct operation of the devices.

So as to enable the performance of service inspections, as well as service and warranty actions such as visual inspections or repairs, it is mandatory that the User provide the physical access to the devices, e.g. by the disassembly of thermal insulation, suspended ceilings, other systems, if they block the free access to the device etc.

In the case of devices installed in ducts, it is recommended preparing inspection pits, e.g. mcr KRW type.

If the devices are installed on the roof, ensure the access to the roof (ladder/lift).

As regards technical inspections, maintenance works and servicing of the devices, please contact the representative of „MERCOR” S.A. Service Department, serwis@mercor.com.pl, tel. 058/ 341 42 45 at 170 or fax 058/ 341 39 85 between 8 and 16 (Mon-Fri).

9. WARRANTY TERMS

1. "MERCOR" SA grants 12 months of warranty for the equipment quality from the date of purchase, unless the sales contract states otherwise.
2. Submit each warranty claim to "MERCOR" SA in 7 days from the date of discovery of a warranty eligible defect
3. Submit warranty claims by calling at: tel. +48 58 341 42 45, by fax: +48 58 341 39 85, by e-mail: reklamacje@mercor.com.pl or by traditional mail: "MERCOR" SA, ul. Grzegorza z Sanoka 2, 80-408 Gdańsk, Poland.
4. If physical defects of equipment are found during the warranty period, "MERCOR" SA warrants and represents to remove them in shortest possible time from serving the written warranty claim with the proof of purchase or sales contract, subject to Item 10.
5. "MERCOR" SA has the right to extend the time of repair if the defect removal is complicated or requires purchase of custom components or spare parts.
6. The warranty liability only covers all defects arising from causes present in the equipment at the date of sale.
7. Defects caused by improper operation or otherwise as listed in Item 10 herein, the buyer / warranty beneficiary will be charged with the costs of their removal.
8. Condition for rectifying defects is that the applicant makes the site/localisation where devices are installed available, in particular, ensuring: the lift in the case of devices mounted at a height above 3m, free access to the rooms where the devices were installed and necessary revisions, dismantling thermal insulation, disassembling suspended ceilings, disassembling other installations, if they prevent free access to the device.
9. If the device can not be repaired at the place of its installation, "MERCOR" SA reserves the necessity of its disassembly, possible delivery to the address indicated by "MERCOR" SA and re-assembly. The cost of this operation lies with the buyer / holder of the guarantee.
10. The warranty does not cover:
 - Any damage or failure of the equipment caused by improper operation, tampering, failure to conduct periodic technical inspection and/or maintenance established in the Operating and Maintenance Manual, section "SERVICING AND MAINTENANCE".
 - Any damage beyond reasonable control of "MERCOR" SA, and specifically: caused by force majeure, such as torrential rainfall, flooding, hurricanes, inundation, lightning strike, power grid overvoltage, explosion, hail, collision with aircraft, fire, avalanche, landslide and indirect damage due to those causes. Torrential rainfall is understood as any rainfall with the effectiveness factor of 4 or higher in accordance with the definition of the Polish Institute of Meteorology and Water Management - National Research Institute (IMGW-PIB). If the effectiveness factor value specified in the preceding sentence cannot be reasonably established, the actual condition and extent of damage shall be considered at the site of their origin as the action of torrential rain. Hurricane is understood as any wind with a minimum speed of 17.5 m/s (and damage shall be recognised as caused by hurricanes if the effects of such weather phenomenon has been found in the direct vicinity of the damaged property).
 - Damage due to failure to immediately report any defect found.
 - Deterioration in the quality of coatings due to natural weathering/ageing.
 - Defects caused by abrasive or aggressive cleaning agents.
 - Damage caused by aggressive external influence, specifically chemical or biological in nature, or when the origin of which is related to the production processing or activity carried out within the facility protected by the equipment or in its direct vicinity.
 - Wearing parts and consumables (e.g. gaskets/seals), unless they have defects of workmanship and/or material.
 - Damage caused by improper transport, handling, unloading and/or storage of the equipment.
 - Damage caused by installation of the equipment in violation of this Operating and Maintenance Manual and/or good construction practice.
 - The equipment and/or parts thereof with removed or damaged nameplate (rating plate) and/or warranty seals.
11. The buyer/warranty rights holder is required to operate the equipment properly and carry out technical inspection and maintenance in accordance with the section "MAINTENANCE AND SERVICING" in the following Operating and Maintenance Manual.
12. This warranty shall be made immediately void and null if:

- The buyer/warranty rights holder modifies the product design without prior authorisation from “MERCOR” SA.
- Periodic technical inspection and/or maintenance is not carried out per schedule and/or is carried out by unauthorised personnel or service providers not authorised to do so by “MERCOR” SA and/or the equipment has not been properly operated.
- Unauthorised personnel attempts any intervention in the product outside of the normal operation and maintenance of this equipment.

13. Any circumstances listed in Item 10 will relieve “MERCOR” SA from the obligation of surety.

As regards any other matters unregulated by these warranty terms, appropriate provisions of the Civil Code shall apply.